



## GT PLUS

High Efficiency Motor



GT PLUS 45 BK  
Cod. **02030407** EAN **8422248087360**

- Mechanical Control Panel**
- 3 extraction levels
- Extraction power (according to UNE/EN 61591): **645m3/h** - 300m3/h
- Maximum air flow (free outlet): **1115m3/h**
- Sound power (Reg.(EU) n°65/2014): 50dB(A)**, maximum: 65dB(A)
- BT2 motor. Extra silent. Maximum energy consumption **200W**
- High efficiency Led lighting**
- Halogen Lighting (Out of EU)**
- Easy-to-install system
- Dishwasher-washable filters
- Finished in Stainless steel, white or black
- Max. Pressure: 400 Pa
- 150/125 mm Outlet diameter
- Energy Class: C

► **Accessories (not included)**

Active charcoal filter .....Cod. 02859398 / EAN 8422248075497.....  
Check valve .....Cod. 02832004 / EAN 8422248480499 .....

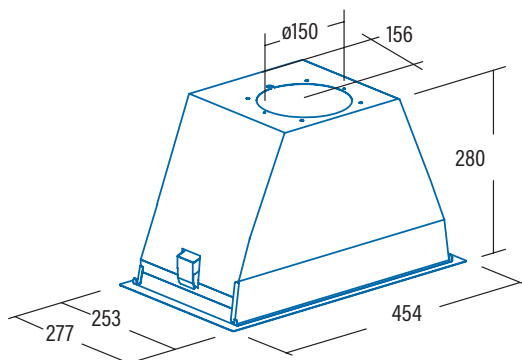

<b>Code</b>	<b>02030407</b>
<b>EAN</b>	<b>8422248087360</b>
<b>Model</b>	<b>GT-PLUS 45 BK</b>
<b>Type</b>	Canopy
<b>Product fiche according to directives EU65/2014 - EN61591, EN60704-2-13, EN50564</b>	
AEC (Annual Energy consumption) (kWh/annum)	90,3
EEL class (Energy Efficiency Class)	C
FDE (Fluid Dynamic Efficiency)	16,3
FDE class (Fluid Dynamic Efficiency Class)	D
LE (Lighting Efficiency) (lux/W)	24,3
LE class (Lighting Efficiency Class)	B
GFE (Grease Filtering Efficiency)	91,2
GFE Class (Grease Filtering Efficiency class)	B
Air flow at minimum speed (m³/h)	300
Air flow at maximum speed (m³/h)	645
Air flow at intensive speed (TURBO) (m³/h)	-
Sound Power Level at minimum speed (dB)	50
Sound Power Level at maximum speed (dB)	65
Sound Power Level at intensive speed (TURBO) (dB)	-
Po (Power Consumption in off mode) (W)	0
Ps (Power Consumption in standby) (W)	0
<b>Integration directive EU 66/2014</b>	
f (Time Increase Factor)	1,4
EEL (Energy Efficiency Index)	82,2
QBEP (Flow Rate at Best Efficiency Point) (m³/h)	358,1
PBEP (Static Pressure Difference at Best Efficiency Point) (Pa)	270
WBEP (Electric Power Input at Best Efficiency Point) (W)	164,9
WL (Nominal Power Consumption of Lighting system) (W)	7
EMIDDLE (Average Illumination of Lighting system on Cooking surface) (lux)	170
<b>External Dimensions</b>	
Width (mm)	492
Depth (mm)	277
Total max height (mm)	280
Total min height (mm)	280
Outlet Diameter (mm)	150/125
<b>Characteristics</b>	
Motor	BT2
Extraction Levels	3
Motor Maximum Power Consumption	200
Maximum Pressure	400
Intensive Speed (TURBO) Pressure	-
Control Type	Mechanic
Automatic shut-down timer	-
Electronic Filter Saturation Indicator	-
Filter Type	Metallic
Anti-grease Filter Number	2
Inner Shield	-
<b>Lighting</b>	
Light Type	EcoLed
Adjustable Intensity Lighting	-
N° of Lamps	2
<b>Installation</b>	
Minimum height distance to a electric worktop hob (mm)	550
Minimum height distance to a gas worktop hob (mm)	650
Installation with Outlet tube to the exterior / Recirculating	BOTH
Easy Installation System	√
<b>Electric Connection</b>	
Total Rush Power (W)	207
Rated Voltage (V)	220-240
Network Frequency (Hz)	50
Electrical Insulation Class	CLASS II
Plug	EU - 2 pins
<b>Accessories</b>	
Upper Decorative tube Extension	-
White Decorative Tube	-
Black Decorative Tube	-
Island Tube Enhancer	-
Check Valve	02832004
MAX PRO Metal Filter	-
Metal Filter	02811000*
DUAL Filter (metal + active charcoal)	02811003
Active Charcoal Filter	02859398
Noiseless Flexible Duct	02893002