

**DL10**

**User Manual**



## **Federal Communications Commission Statement**

NOTE: This equipment has been tested and found to comply with the limits for a Class A digital device, pursuant to part 15 of the FCC Rules. These limits are designed to provide reasonable protection against harmful interference when the equipment is operated in a commercial environment. This equipment generates, uses, and can radiate radiofrequency energy and, if not installed and used in accordance with the instruction manual, may cause harmful interference to radio communications. Operation of this equipment in a residential area is likely to cause harmful interference in which case the user will be required to correct the interference at his own expense.

FCC Caution: Any changes or modifications not expressly approved by the party responsible for compliance could void the user's authority to operate this equipment.

This device complies with part 15 of the FCC Rules.

Operation is subject to the following two conditions:

- (1) This device may not cause harmful interference, and
- (2) this device must accept any interference received, including interference that may cause undesired operation.

**Warning** - This is a class A product. In a domestic environment, this product may cause radio interference in which case the user may be required to take adequate measures.

This Class A digital apparatus complies with Canadian ICES-003.

Cet appareil numérique de la classe A est conforme à la norme NMB-003 du Canada.

## **Caution**

Risk of explosion if battery is replaced by an incorrect type.

Dispose of used batteries in a safe and proper manner.

## **Remote Control Battery Safety Information**

- Store batteries in a cool and dry place.
- Do not throw away used batteries in the trash. Properly dispose of used batteries through specially approved disposal methods.
- Remove the batteries if they are not in use for long periods of time. Battery leakage and corrosion can damage the remote control. Dispose of batteries safely and through approved disposal methods.
- Do not use old batteries with new batteries.
- Do not mix and use different types of batteries: alkaline, standard (carbon-zinc) or rechargeable (nickel-cadmium).
- Do not dispose of batteries in a fire.
- Do not attempt to short-circuit the battery terminals.

## **DISCLAIMER**

No warranty or representation, either expressed or implied, is made with respect to the contents of this documentation, its quality, performance, merchantability, or fitness for a particular purpose. Information presented in this documentation has been carefully checked for reliability; however, no responsibility is assumed for inaccuracies. The information contained in this documentation is subject to change without notice.

In no event will AVer Information Inc. be liable for direct, indirect, special, incidental, or consequential damages arising out of the use or inability to use this product or documentation, even if advised of the possibility of such damages.

## **TRADEMARKS**

“AVer” is a trademark owned by AVer Information Inc. Other trademarks used herein for description purpose only belong to each of their companies.

## **COPYRIGHT**

© 2022 AVer Information Inc. All rights reserved.

All rights of this object belong to AVer Information Inc. Reproduced or transmitted in any form or by any means without the prior written permission of AVer Information Inc. is prohibited. All information or specifications are subject to change without prior notice.

## **NOTICE**

SPECIFICATIONS ARE SUBJECT TO CHANGE WITHOUT PRIOR NOTICE. THE INFORMATION CONTAINED HEREIN IS TO BE CONSIDERED FOR REFERENCE ONLY.

## WARNING

- To reduce the risk of fire or electric shock, do not expose this appliance to rain or moisture. Warranty will be void if any unauthorized modifications are done to the product.
- Do not drop the camera or subject it to physical shock.
- Use the correct power supply voltage to avoid the damaging camera.
- Do not place the camera where the cord can be stepped on as this may result in fraying or damage to the lead or the plug.
- Hold the bottom of the camera with both hands to move the camera. Do not grab the lens or lens holder to move the camera.

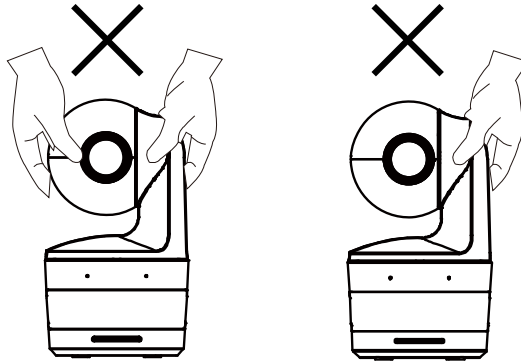

**OK**

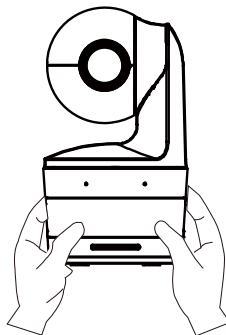

## **More Help**

For FAQs, technical support, software and user manual download, please visit:

### **Headquarters**

Download Center: <https://www.aver.com/download-center>

Technical Support: <https://www.aver.com/technical-support>

### **USA Branch office**

Download Center: <https://www.averusa.com/education/support>

Technical Support: <https://averusa.force.com/support/s/contactsupport>

### **Europe Branch office**

Download Center: <https://www.avereurope.com/download-center>

Technical Support: <https://www.avereurope.com/technical-support>

## Contact Information

### **Headquarters**

AVer Information Inc.

<https://www.aver.com>

8F, No.157, Da-An Rd., Tucheng Dist., New Taipei City 23673, Taiwan

Tel: +886 (2) 2269 8535

### **Europe Branch office**

AVer Information Europe B.V.

<https://www.aveurope.com>

Westblaak 134, 3012 KM, Rotterdam, The Netherlands

Tel: +31 (0) 10 7600 550

Technical support: [eu.rma@aver.com](mailto:eu.rma@aver.com)

### **USA Branch office**

AVer Information Inc., Americas

<https://www.averusa.com>

668 Mission Ct., Fremont, CA 94539, USA

Tel: +1 (408) 263 3828

Toll-free: +1 (877) 528 7824

Technical support: [support.usa@aver.com](mailto:support.usa@aver.com)

### **Japan Branch Office**

アバー・インフォメーション株式会社

<https://jp.aver.com>

〒160-0023 日本東京都新宿区西新宿 3-2-26 立花新宿ビル 7 階

Tel: +81 (0) 3 5989 0290

テクニカル・サポート: [Support.EDU.JP@aver.com](mailto:Support.EDU.JP@aver.com)

### **Vietnam Branch Office**

Công ty TNHH AVer Information (Việt Nam)

Tầng 5, 596 Nguyễn Đình Chiểu, P.3, Quận 3,

Thành phố Hồ Chí Minh 700000, Việt Nam

Tel: +84 (0) 28 22 539 211

# Contents







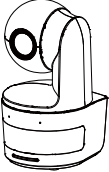
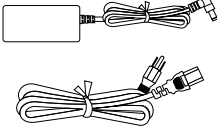
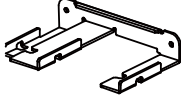
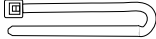

Package Contents.....	1
Camera Mount Suggestions (Optional Accessories).....	1
Product Introduction .....	2
Overview.....	2
LED Indicator.....	2
Pan and Tilt Angle.....	3
Dimension.....	3
Cable Fixing Plate Installation.....	4
Device Connection.....	5
Connections.....	6
Audio Input Connection .....	7
Ceiling Mount Installation (Optional).....	8
Wall Mount Installation (Optional) .....	9
Camera Setup Recommendations.....	11
Remote Control.....	12
Hot Key.....	13
Set Up the Camera .....	13
Set Up IP Address of the Camera.....	13

If there is DHCP environment.....	13
Or if you want to configure by yourself .....	13
Web Setup .....	14
Use the AVer IPCam Utility to Find the Camera .....	14
Make a Connection to the Camera via Browser.....	15
Live View .....	16
Snapshot .....	16
Pan-Tilt-Zoom Control .....	17
Manual Pan-Tilt Speed Adjustment.....	17
Focus.....	18
Preset Position .....	18
Tracking Control .....	19
Settings.....	20
Tracking Settings.....	20
Tracking Control .....	20
Presenter.....	21
Zone .....	23
Hybrid .....	25
Camera Settings.....	27
Camera Control .....	27

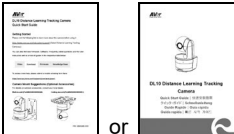

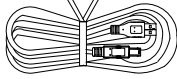
Preset.....	28
Exposure .....	29
Image Process .....	29
System .....	32
FAQ.....	35
Specification** .....	37

# Package Contents

<p>Camera Unit</p>	<p>Power Adapter (1.2 m/3.93 ft) Power Cord (1.83 m/6.00 ft)</p>	<p>Cable Fixing Plate</p>	<p>Cable Ties (x3)</p>
			
<p>M2 x 4mm Screws (x2)</p>	<p>Quick Start Guide</p>	<p>Remote Control</p>	<p>USB Cable (1.5 m/4.92 ft)</p>
			
<p>1/4"-20, L=7.5mm Screw</p>	<p>User Manual*</p>	<p>Warranty Card*</p>	
			

\*Only for Japan

## Camera Mount Suggestions (Optional Accessories)

For details on optional accessories, consult your local dealer.

Wall mount

USA: Part#PTMLTWM01

Other countries: Part#60S5000000AB

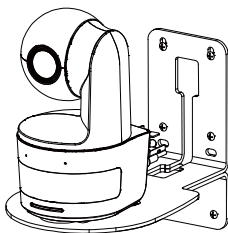

Ceiling mount

USA: Part#PTMLTCM02

Other countries: Part#60S5000000AC

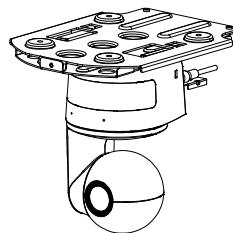

# Product Introduction

## Overview

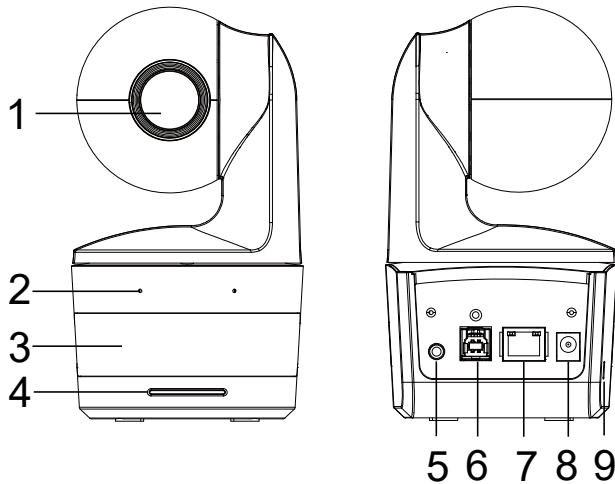

(1) Camera Lens	(4) LED Indicator	(7) Ethernet Port
(2) Built-in Microphones	(5) Audio In*	(8) DC Power Jack
(3) IR Sensor	(6) USB Port	(9) Kensington Lock

\*Line input level: 1Vrms (max)

\*Mic input level: 50mVrms (max); Supplied voltage: 3.3V

## LED Indicator

LED	Status
Blue (Blinking every 2 seconds)	Tracking On
Blue (Solid)	Normal Operation and Tracking Off
Orange (Blinking)	Camera Initialization
Orange (Solid)	Standby Mode
Red (Blinking)	Firmware Update
Purple (Blinking for 3 times)	RTMP being switched on or off
Green (Blinking)	Gesture control command received

## Pan and Tilt Angle

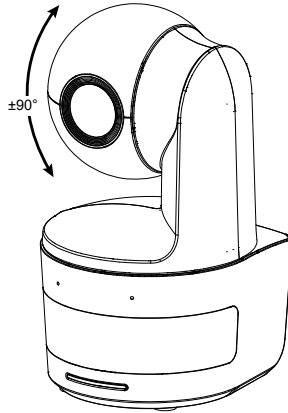
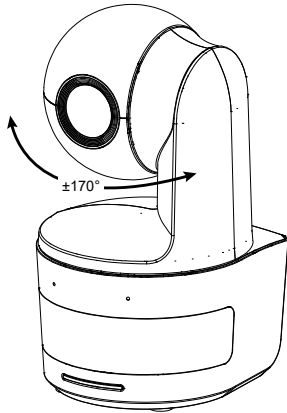

## Dimension

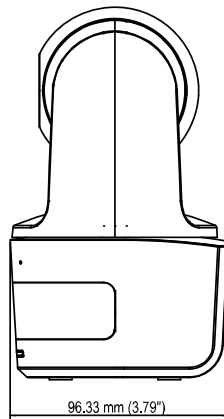
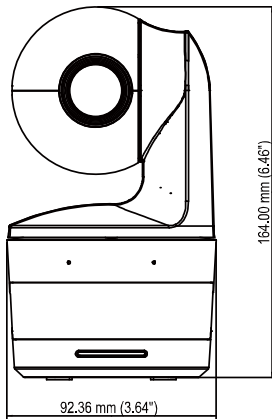

## Cable Fixing Plate Installation

1. Secure the cable fixing plate to the camera with two M2 x 4 mm screws in the package.

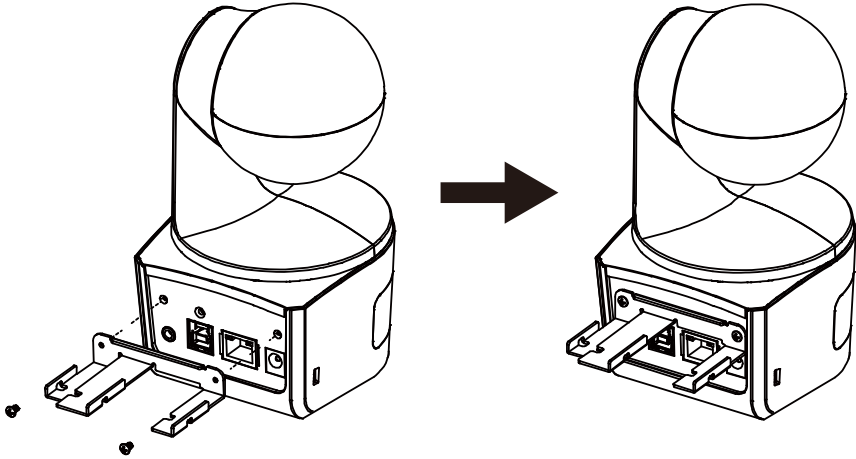

2. Plug in cables.

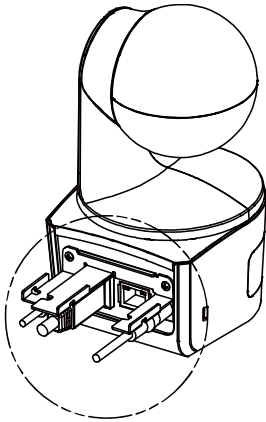

3. Use 3 cable ties in the package to secure the cables and cable fixing plate.

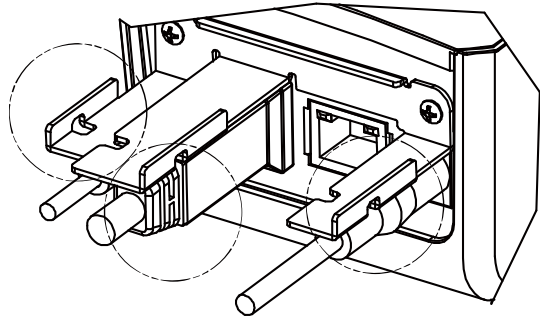

# Device Connection

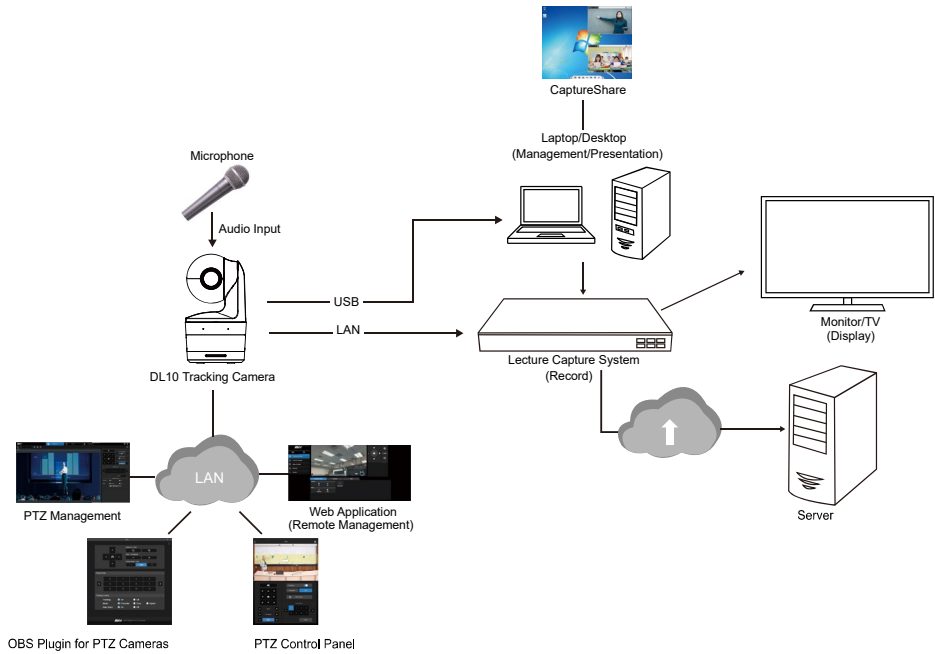

# Connections

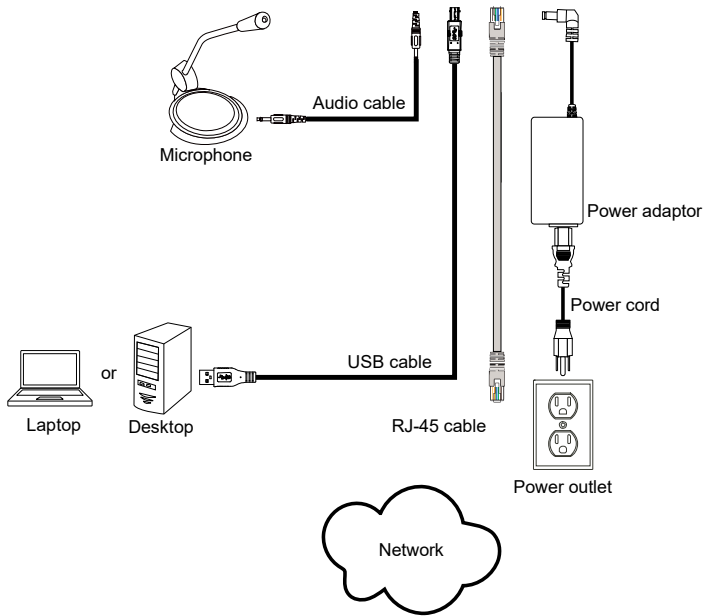
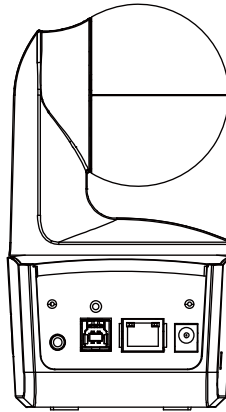

## Audio Input Connection

Connect the audio device for audio receiving.

### [Note]

1. Line input level: 1Vrms (max)
2. Mic input level: 50mVrms (max); Supplied voltage: 3.3V
3. Because video conferencing software such as Google Hangouts (Windows), Skype (Mac), or Teams (Windows and Mac) can automatically adjust volume, the user might experience randomly unstable volume while using the camera.

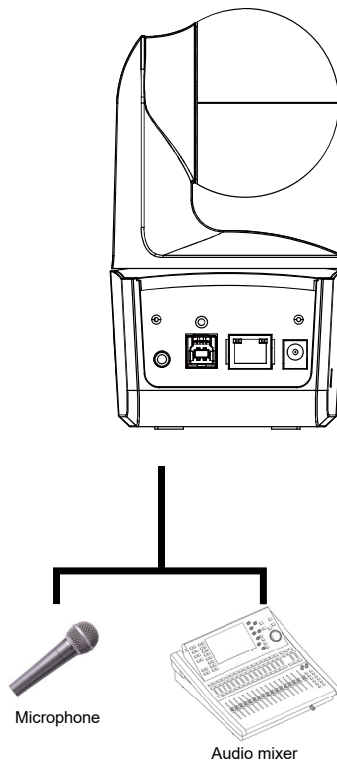



## Ceiling Mount Installation (Optional)

1. Use two M2 x 4mm screws (in the DL camera package) to secure the cable fixing plate (in the DL camera package) to the camera. Plug in cables. Use 3 cable ties (in the DL camera package) to secure the cables and cable fixing plate.
2. Use four M4 (L≥10mm) screws (not supplied) to secure the mount bracket on the ceiling.
3. Use one 1/4"-20, L=7.5mm screw (in the ceiling mount kit) to install another mount bracket on the camera.
4. Slide the mount bracket with the camera into the mount bracket secured on the ceiling.
5. Use three M3 x 6mm screws (in the ceiling mount kit) to secure the camera.

①

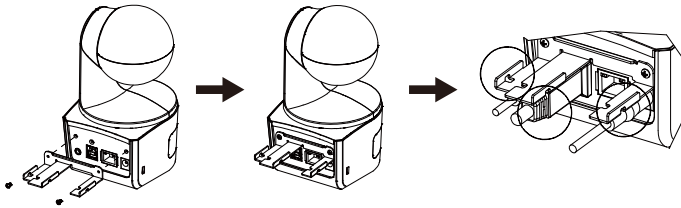

②

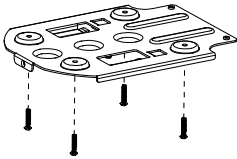

③

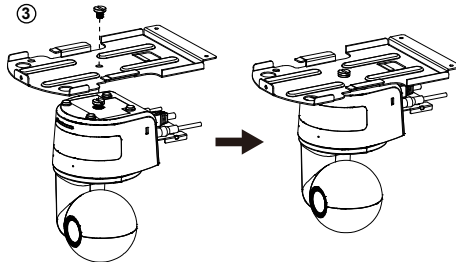

④

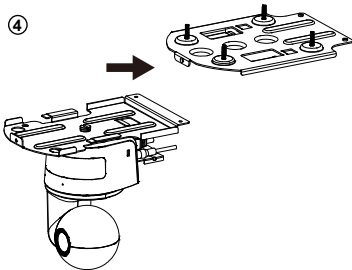

⑤

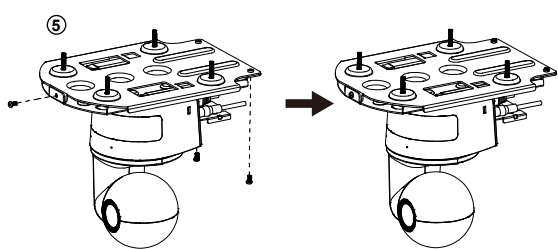

## Wall Mount Installation (Optional)

1. Use two M2 x 4mm screws (in the DL camera package) to secure the cable fixing plate (in the DL camera package) to the camera. Plug in cables. Use 3 cable ties (in the DL camera package) to secure the cables and cable fixing plate.
2. Use the drilling paper included in the package to drill the holes in the wall where the user wants to mount the camera.
3. Use the screws specified below (not included) to secure the L-mount bracket onto the wall.

**[Note]** For cement wall: M4 x 20mm self-tapping screws (x4) + plastic conical anchor

For wooden wall: M4 x 20mm self-tapping screws (x4)

4. Then, assemble the L-mount brackets + with 2 screws (M4 x 8mm, included in the package).

①

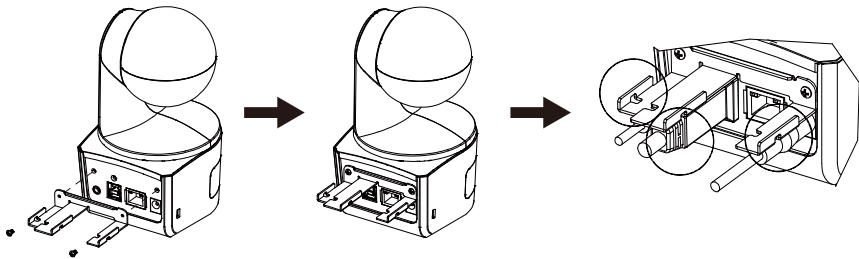

②

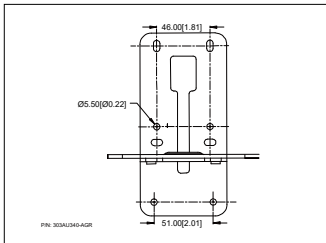

③

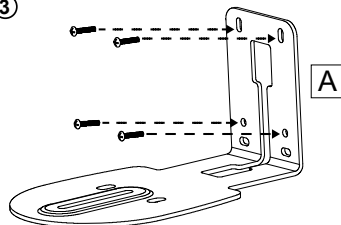

④

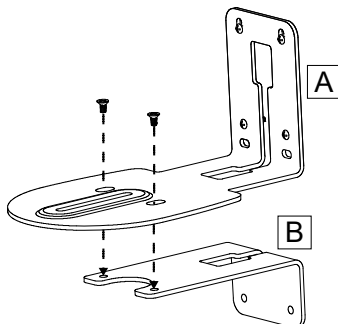

- After assembling the L-mount brackets, use the screws specified below (not included) to secure the lower part of L-mount brackets onto the wall.

**[Note]** For cement wall: M4 x 20mm self-tapping screws (x2) + plastic conical anchor

For wooden wall: M4 x 20mm self-tapping screws (x2)

- Pass the cables through the hole on the L-mount brackets and connect the cables to their corresponding connection ports.
- Use the remaining screw (1/4"-20, L=7.5mm, included in the package) to secure the camera on the L-mount brackets.

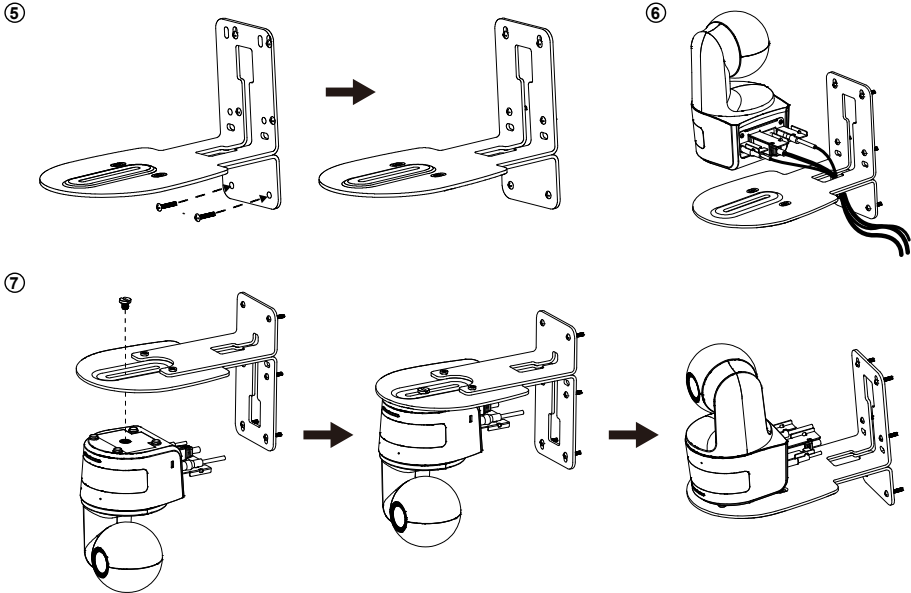

# Camera Setup Recommendations

- **Angle A:** less than 30°
- **Height B:** 2~2.5 m from floor, 2 m is suggested.
- **Distance C:** 1.5~5 m
- **Distance between the camera and tracking target (presenter):**

Optical zoom ratio ability	Upper body size	Full body size
3X	3 m (9.84 ft)	5 m (16.4 ft)

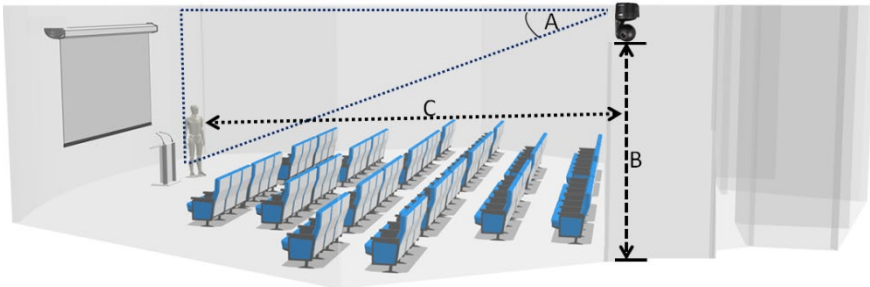

- **Example of distances with equivalent angle values**

Angle A	Height B	Distance C
25°	2 m (6.56 ft)	4.3 m (14.1 ft)
28°	2.3 m (7.55 ft)	4.3 m (14.1 ft)
28°	2.5 m (8.2 ft)	4.7 m (15.4 ft)

- **Position:** center of classroom

**[Note:]**

- No human outline on poster/screen/monitor/TV in the background.
- No more than three people in a single camera view.

## Remote Control

The remote control requires two “AAA” size batteries. Make sure batteries are installed properly before use.

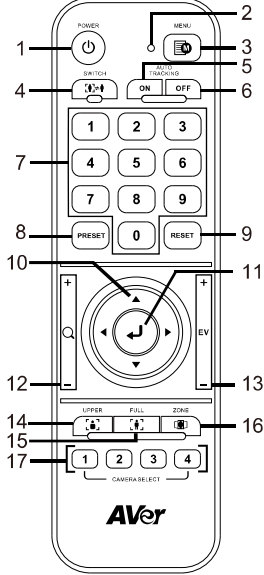
	Name	Function
	(1) Power	Turn the unit on/standby/privacy: <ul style="list-style-type: none"> <li>■ Press once to turn on privacy mode. Press again to turn off privacy mode.</li> <li>■ Long press for 3 seconds to turn on standby mode. Short press again to turn off standby mode.</li> </ul>
	(2) Remote Control LED	It will be on when pressing other buttons.
	(3) Menu	Open and exit the OSD menu. <b>[Note]</b> DL10 does not support OSD menu.
	(4) Switch	Switch from presenter to another presenter.
	(5) Auto Tracking On	Turn on auto tracking.
	(6) Auto Tracking Off	Turn off auto tracking.
	(7) Number buttons	Use for setting the preset position 0~9.
(8) Preset	To set a preset position: Press <b>“Preset”</b> and then press <b>“Number button (0~9)”</b> . Remote control LED and camera button LED will not light when pressing Preset button alone.	
(9) Reset	To cancel a pre-configured preset position: Press <b>“Reset”</b> and then press <b>“Number button (0~9)”</b> . Remote control LED and camera button LED will not light when pressing Reset button alone.	
(10) ▲, ▼, ◀, & ▶	Pan and tilt the camera. Pan/Tilt speed by remote control is fixed. You may change pan/tilt speed by using web browser. For setting details of web browser, please refer to Set Up the Camera section.	
(11) Enter	Use the Enter button to send the camera to the Home position.	
(12) Zoom In/Out	Zoom in/out. Zoom in/out speed by remote control is fixed. You may change zoom in/out speed by using web browser. For setting details of web browser, please refer to Set Up the Camera section.	
(13) EV +/-	EV level adjustment. *Press EV+ for three seconds to switch on RTMP. *Press EV- for three seconds to switch off RTMP.	
(14) Upper Body	Tracking mode switches to Presenter Mode when pressing Upper Body button, and presenter's size on screen is upper body.	
(15) Full Body	Tracking mode switches to Presenter Mode when also pressing Full Body button, and presenter's size on screen is full body. Upper Body focuses on the presenter from his/her knees to the top of the head whereas the Full Body captures the whole outline of the presenter from his/her feet to the top of the head.	

(16) Zone	Tracking mode switches to Zone Mode when pressing Zone button.
(17) Camera Select	CAM1 to CAM4 buttons. Select a camera to operate. Once a camera is selected, the CAM button LED will be on when pressing other buttons. If only one AVer camera is connected, then the default is CAM1.

## Hot Key

Press certain button on remote control to perform hot key function.

Button	Action	Function
5	Press five times (55555)	Turn on DHCP.
8	Press eight times (88888888)	Set DL camera's IP address as default IP (192.168.1.168).
9	Press nine times (999999999)	Password reset mechanism: When the hot key takes effect, the password of entering Web UI will go back to the default "admin".

## Set Up the Camera

### Set Up IP Address of the Camera

DL camera's default setting is DHCP on.

#### If there is DHCP environment

1. Connect your camera to the internet and wait for your camera to get IP address.
2. From your server, you can find your new camera IP address.
3. If necessary, modify the IP address.

#### Or if you want to configure by yourself

1. Use the remote control and press the button "8" eight times to switch to Static IP mode.
2. The default IP for the camera would be set to 192.168.1.168.
3. Set up your computer with static IP 192.168.1.x and then type in 192.168.1.168 in your web browser to access the camera.

## Web Setup

Connect the camera from a remote site through the Internet.

### Use the AVer IPCam Utility to Find the Camera

To find the IP address of your cameras, you can execute the IPCam Utility installer. Follow the below steps to find the IP address of the camera.

1. Download the IPCam Utility from  
Global: <https://www.aver.com/download-center>  
USA: <https://www.averusa.com/education/support>  
Europe: <https://www.avereurope.com/download-center>
2. Run the IPCam Utility.
3. Click Search, and all available devices will be listed on the screen.
4. Select a camera from the list.
5. The corresponding fields of IP address will display.
6. Double-click on the IP address of the camera from the list to connect to the camera through the browser.

**[Note]** If IPCam utility cannot find the camera, please check following:

1. Please make sure the Ethernet connection of camera is well connected.
2. The camera and PC (IPCam utility) are in the same LAN segment.

AVer IPCam Utility v2.7.1029.34

Network Device: Realtek PCIe GbE Family Controller [Search]

Login: User ID [ ] Password [ ]

Network Setting | Date/Time Setting | Maintenance | Import/Export Config

Search Result: [Select All]

No.	Status	Progress	Model Name	Device Name	FW version	IPv4 Address	MAC Address	IPv6 Address
<input type="checkbox"/> 1	Working		DL30	DL30	7.0.0022.26	10.100.90.16:80	00:30:1b:ba:02:db	[fe80::]:80
<input type="checkbox"/> 2	Working		DL10	DL10	0.0.1000.60	10.100.90.15:80	00:18:1a:6e:51:27	[]:80

Settings:

Device Name: [ ]

Start IP Address: [ . . . ]

End IP Address: [ . . . ]

Subnet Mask: [ . . . ]

Gateway: [ . . . ]

Primary DNS: [ . . . ]

Secondary DNS: [ . . . ]

DHCP  
 Static IP

\*Auto search will start after settings changed!  
 Don't start auto search this time!

[Apply]

## Make a Connection to the Camera via Browser

Open the browser and enter the IP address of the camera. The PC/laptop requires an internet access. After connecting to the camera, enter the user account and password (default is **admin/admin**) to log in Web.



### [Note]

- User will be asked to set a new account and password after first login. Please use the new account and password to log in later.
- If you forget the login account or password that you previously set for the webpage, you may press number 9 nine times (999999999) on your remote control, then the camera webpage login account and password will go back to the default "admin".

The image shows a 'Login' dialog box with a dark background. At the top, it says 'Login'. Below that, it prompts the user: 'Please change new Name & Password for login'. There are two input fields: 'Login Name' with a person icon to its left, and 'Login Password' with a lock icon to its left. At the bottom of the dialog, there are two buttons: 'Cancel' and 'Change'.



## Live View

In live view, the user can make a snapshot, set up camera control (zoom in/out, camera direction control, pan/tilt speed, focus), view preset, and tracking control (on, off, tracking mode).





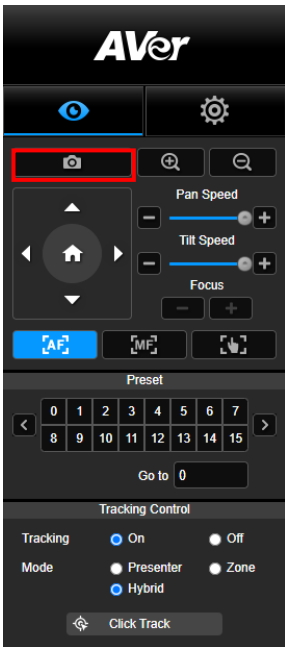



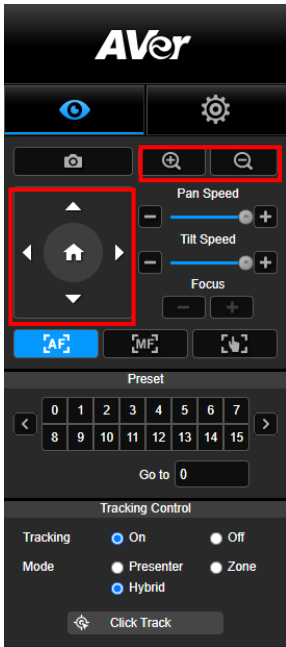

## Snapshot



Select the camera button to make a snapshot and download the file to local storage.

## Pan-Tilt-Zoom Control



To operate the PTZ Camera motion, use , , , and  to adjust the camera view position and use  and  to zoom. Select  to go back to default position.

## Manual Pan-Tilt Speed Adjustment

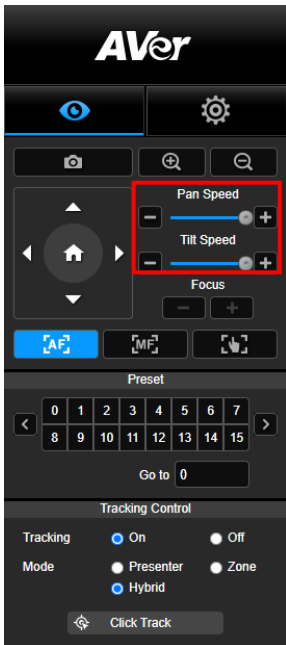

Adjust the speed of manual Pan-Tilt.

**[Note]** The max manual pan speed is 100°/sec. The max manual tilt speed is 100°/sec.

## Focus

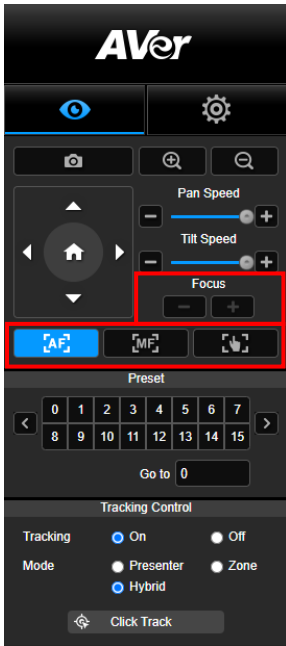

Switch to auto (AF) or manual (MF) focus. The manual focus use “+” and “-” to adjust focus. Select “+” to adjust focus to the far end and focusing on a far subject; select “-” to adjust focus to near end and focusing on a near subject.

**One push focus:** By clicking the  button to adjust Lens focus automatically once.

## Preset Position

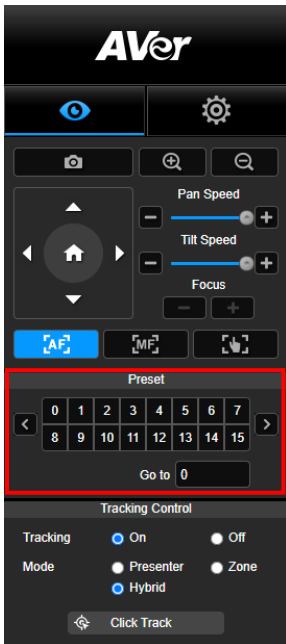

Select the number to view preset positions. User can also enter preset position number (0~255) in “Go to” column directly for a quickly calling section.

## Tracking Control

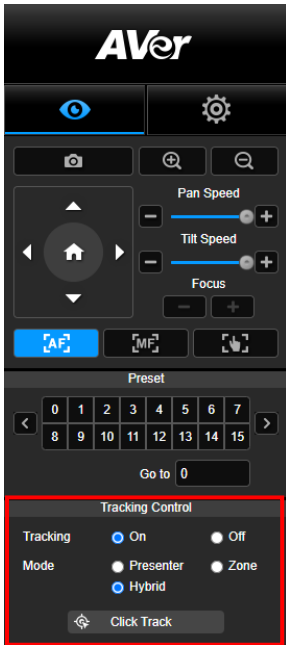

Enable/disable tracking function, select tracking mode, and operate one-click tracking function.

- **Tracking mode** (refer to [Tracking Settings](#) section for setup)

- **Presenter:** Camera will start tracking when object enters the tracking point.

- [Note]** Tracking point under presenter mode: default set is preset 1. When preset 1 is not set, tracking point is home position.

- **Zone:** Camera will start tracking when object is moving between the preset tracking block area.

- **Hybrid:** With the advantages of both the **Presenter Mode** and **Zone Mode**, the camera tracks and captures the presenter's movement. As the presenter enters the previously configured preset point zone, the camera steers to focus on the content of the zone, such as the whiteboard and the projector screen.

- **Click Track:** This function allows user to change tracking object while auto tracking.

1. Select **Click Track** button. A red frame is targeted on the tracking object and blue frames are targeted on other objects on the live screen.

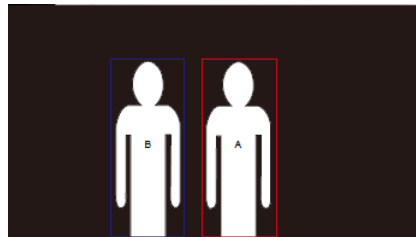

2. To select a new target, just simply click the object on the live screen.

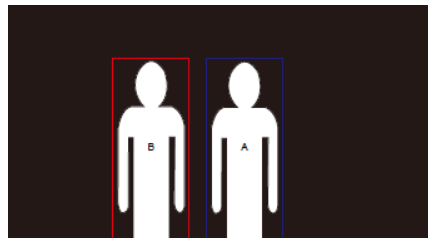

## Settings

### Tracking Settings

Enable/disable tracking function, set up tracking mode, operate one-click tracking function and pan/tilt/zoom the camera.

**[Note]** Tracking will be off when activating pan/tilt/zoom or go to preset point.

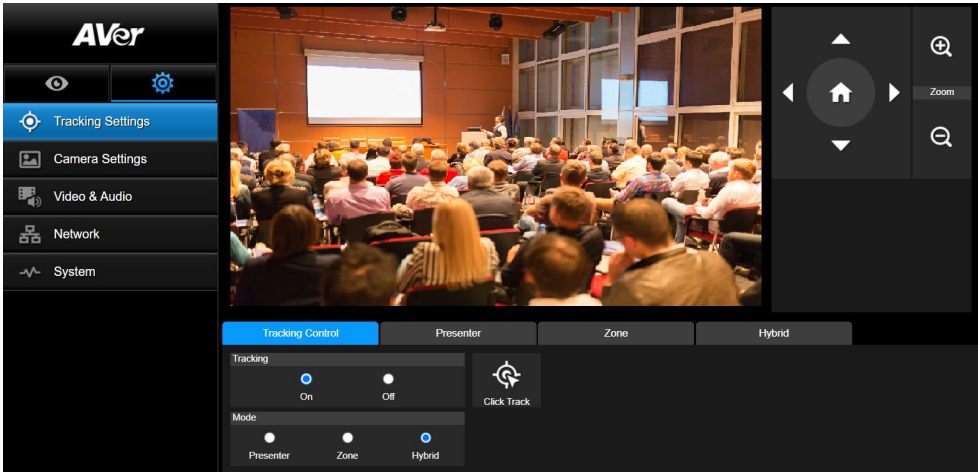

### Tracking Control

Enable/disable tracking function, select tracking mode, operate one-click tracking function (refer to [Tracking Control](#) section), and pan/tilt/zoom the camera.

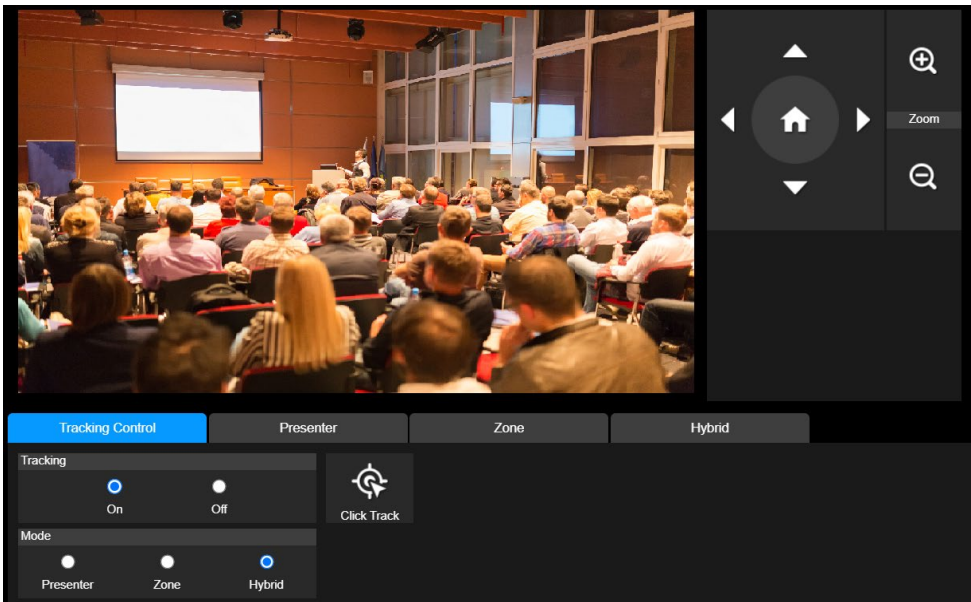





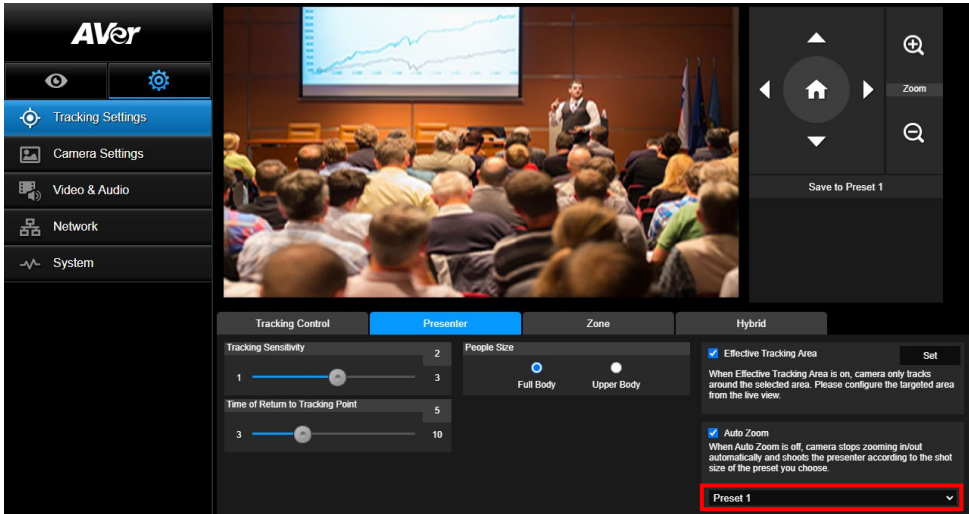

## Presenter

Select the “**Presenter**” tab in Tracking Settings interface.



Camera will start tracking when object enters the tracking point.

1. Use , , , ,  and  to adjust the camera to tracking point.
2. Then, select **Save to Preset 1** to save the tracking point.
3. **Tracking Sensitivity**: sets the sensitive level of tracking. Move bar to set the value. The current value is displayed at upper right corner.
4. **Time of Return to Tracking Point**: sets the idle time for camera return to tracking point. Move bar to set the value. The current value is displayed at upper right corner.
5. **People Size**: selects the people in full or upper body while tracking.

**[Note]** Tracking point under presenter mode: default set is preset 1. When preset 1 is not set, tracking point is home position.

- 6. **Effective Tracking Area:** When Effective Tracking Area function is on, camera only tracks around the selected area. Check the box to turn on the Effective Tracking Area function then click Set to configure the targeted area in the live view. Move the upper left corner and the lower right corner of the red solid frame to define the targeted area.

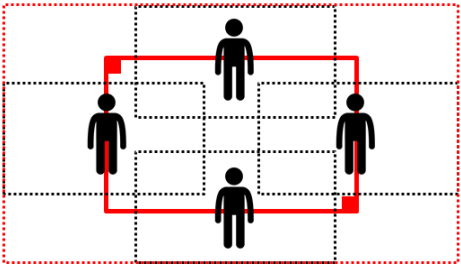
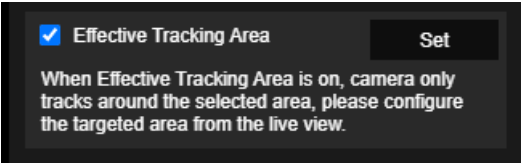

**[Note]** The position of the red solid frame corresponds to the central position of the presenter. The black dotted frames represent the tracking areas for different positions of the presenter. Therefore, the red dotted frame is the actual effective tracking area of the red solid frame.

- 7. **Auto Zoom:** When Auto Zoom is off, camera stops zooming in/out automatically and shoots the presenter according to the shot size of the Preset you choose. Choose a Preset point in the drop-down list.

## Zone

Select the “**Zone**” tab in Tracking Settings interface.

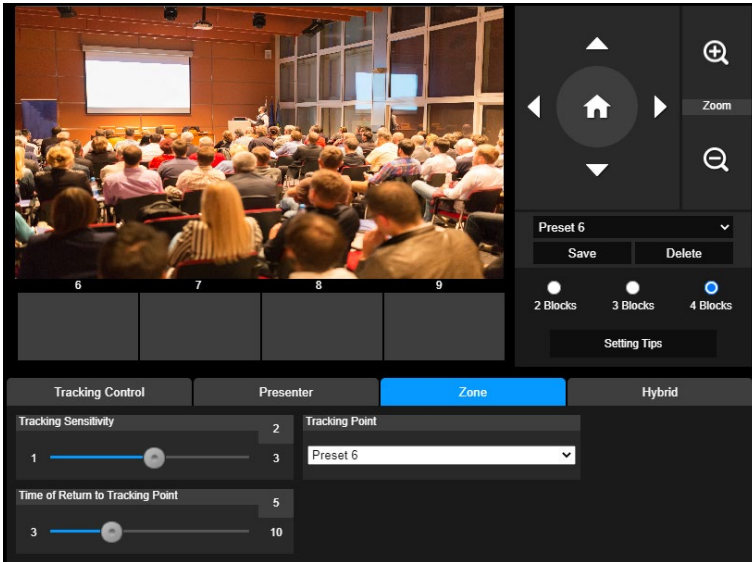





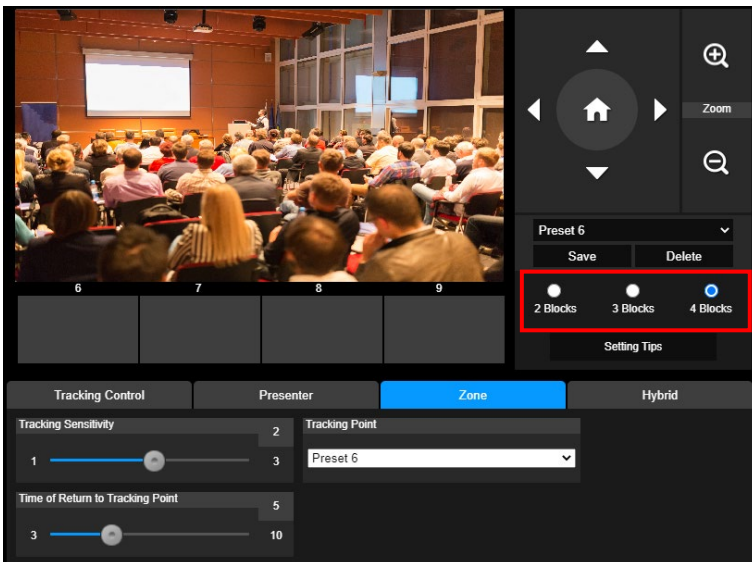

Set up 2 to 4 block areas for the camera. Each block is corresponding to one preset position. Camera will switch between preset positions when the presenter enters different blocks.

1. Select the “**Number of block**” (2, 3, or 4).





2. Select the block and set the preset positions in order (preset 6 to preset 9). Use , , , ,  and  to move the camera to desired position and select "Save" to save the preset position. And, a snapshot of the preset image will show at corresponding image display box. Repeat the steps to set another preset position.

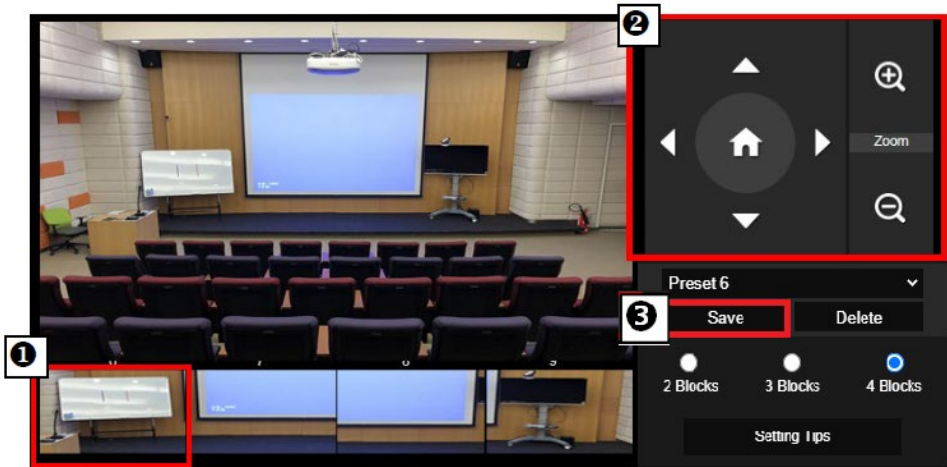

#### [Notes]

- Set each preset overlapping with the next one (one man width).
  - Set the preset view to clearly see at least 60% upper body of the presenter to ensure tracking accuracy. Make sure no other human-outline poster/TV/monitor in the background.
3. **Tracking Sensitivity:** sets the sensitive level of tracking. Move bar to set the value. The current value is displayed at upper right corner.
  4. **Time of Return to Tracking Point:** sets the idle time for camera return to tracking point. Move bar to set the value. The current value is displayed at upper right corner.





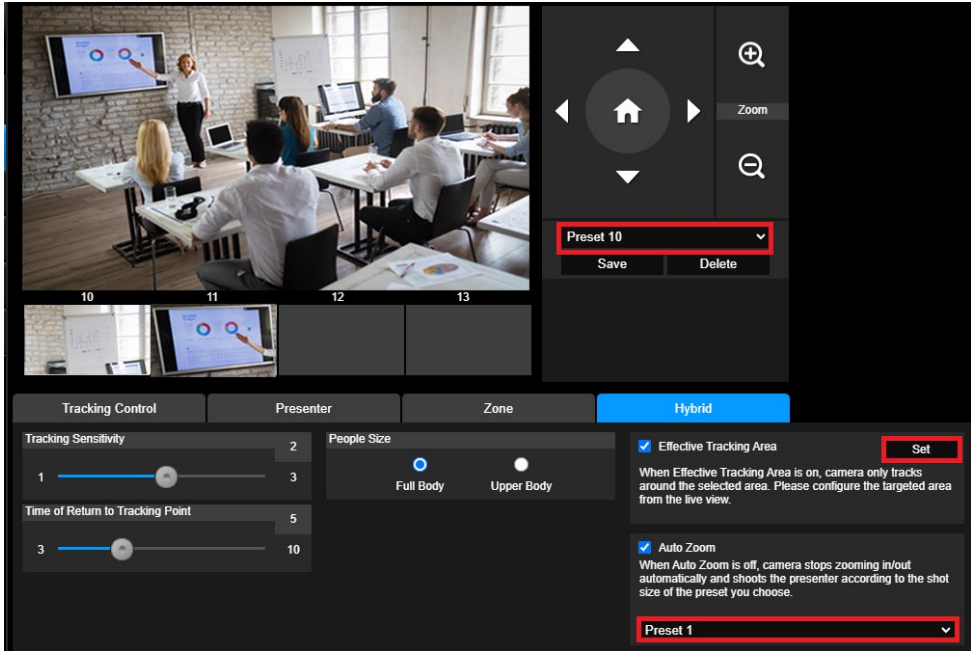

## Hybrid

Under **Tracking Settings**, select **Hybrid**.



**Hybrid** benefits you with the advantages of both the **Presenter Mode** and **Zone Mode**. Under **Hybrid Mode**, the camera tracks and captures the presenter's movement. As the presenter enters the previously configured preset point zone, the camera steers to focus on the content shown on the teaching gadget in the zone, such as the whiteboard and the projector screen.

Firstly, configure **Preset 10-13** to define the preset point zone.

1. Select **Preset 10** from the drop-down menu.
2. Use , , , ,  and  to adjust the camera to the desired angle.
3. Select **Save** to save **Preset 10**.
4. Select **Delete** to remove **Preset 10**. You can proceed to reconfigure **Preset 10**.
5. Repeat the steps above to configure **Preset 11-13**. Leave some space between **Preset 10** to **13**, as each preset point zone is meant to center on the content of the teaching gadget, such as the whiteboard and the projector screen.

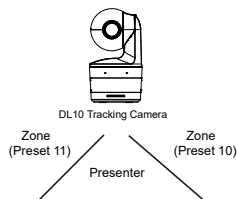

Secondly, determine how the camera tracks the presenter.



- **Tracking Sensitivity:** sets the sensitivity level of tracking. Move bar to set the value. The current value is displayed at upper right corner.
- **Time of Return to Tracking Point:** sets the idle time for camera return to tracking point. Move bar to set the value. The current value is displayed at upper right corner.
- **People Size:** selects the people in full or upper body while tracking.  
**[Note]** Tracking point under presenter mode: default set is preset 1. When preset 1 is not set, tracking point is home position.
- Once the **Effective Tracking Area** is enabled, the camera tracks the presenter only when he/she is within the specified **Effective Tracking Area**. When configuring the **Effective Tracking Area**, include **Preset 10-13** in the **Effective Tracking Area** so that the camera tracks to focus on the content of the preset point zone. For instance, in the case where **Preset 10** is excluded from the **Effective Tracking Area**, even if the presenter walks to the flat TV in **Preset 10**, the camera will not go to **Preset 10** and will not show the content of the flat TV.
- **Auto Zoom:** When auto zoom is off, the camera stops zooming in/out automatically and shoots the presenter according to the shot size of the Preset you choose. Choose a Preset point in the drop-down list.

# Camera Settings

## Camera Control

Select **Settings** (  ) > **Camera Settings** > **Camera Control**.





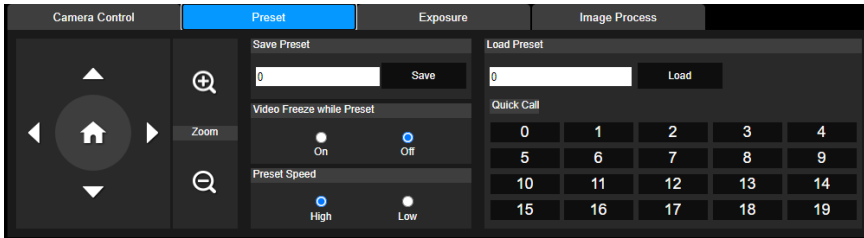

- You can navigate the camera to the desired angle with its **PTZ** function.
- **Auto Focus Modes:**
  - Select . Find the two modes below in the **AF Mode** drop-down list.
  - **AF Trigger after PTZ (Default):** After the camera pans, tilts, or zooms in/out, the auto focus will be triggered once. This mode is suitable for scenarios where the presenter uses gestures and body language but walks around only occasionally. The camera will auto focus on the presenter only once after he/she stops walking, thus stabilizing the footage.
  - **Continuous AF:** The camera automatically maintains its focus on the presenter whenever it detects any movement. This mode is widely used in cases where the presenter strolls around the room, for it can firmly keep focus on the presenter optimally.
- Select  to switch to the **manual focus**. Click the minus sign to focus near and plus sign to focus far.
  - **One push focus:** By clicking the  button to adjust Lens focus automatically once.
- You can adjust the **Pan Speed** of the camera with the slider.
- You can adjust the **Tilt Speed** of the camera with the slider.
- You can select **High** or **Low** for **Zoom Speed**.
- You can select **On** or **Off** for Digital Zoom.

## Preset

Set up preset position and view preset position.



1. Select the “Preset” tab in Camera Settings interface.
2. Use , , , and  to adjust camera view position.
3. Enter preset position number (0~255) in **Save Preset** column and select “**Save**” to save the position.
4. To call the preset position, enter a preset number (0~255) in **Load Preset** column or select the preset number (0~19) from **Quick Call** section.
5. **Video Freeze while Preset**: turns on/off the screen view freeze function. When “**Video Freeze while Preset**” is on, during the preset operation, the screen will freeze until the operation is done.
6. **Preset Speed**: selects the preset speed.

**[Note]** Preset point value includes: pan/tilt/zoom, exposure, shutter, ev, brightness, gain, slow shutter, white balance, focus, focus position, digital zoom, and R&B gain.

## Exposure

Select the “**Exposure**” tab in camera settings interface.

Set up the exposure type - Full Auto or Manual and relevant settings.

**[Note]:** Iris Level configuration is not supported on DL10.

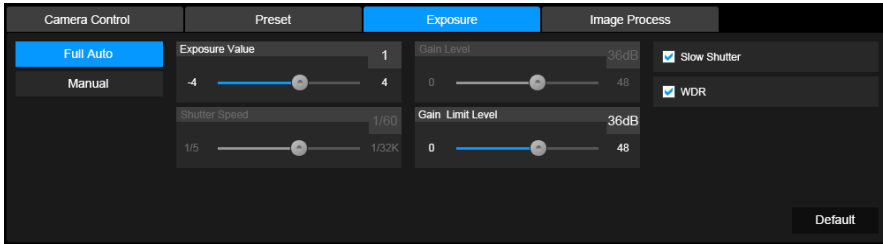

## Image Process

Select the “**Image Process**” tab in camera settings interface.

Set up the white balance, saturation, contrast, sharpness, noise filter, mirror, and flip.

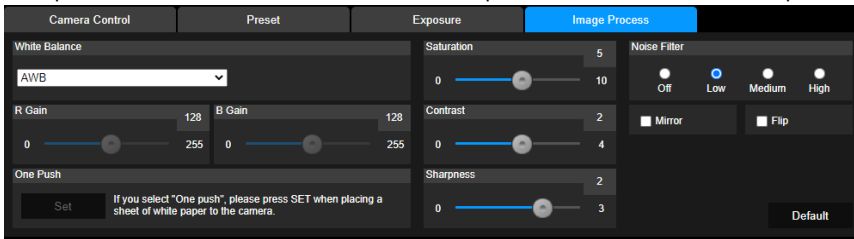

## Video & Audio

The user can set up Power Frequency, Video Mode, Stream Video Output, Bitrate, Encoding Type, Framerate, I-VOP Interval (S), Rate Control, Noise Suppression, External Audio Input, Audio Volume, and Sampling Rate.

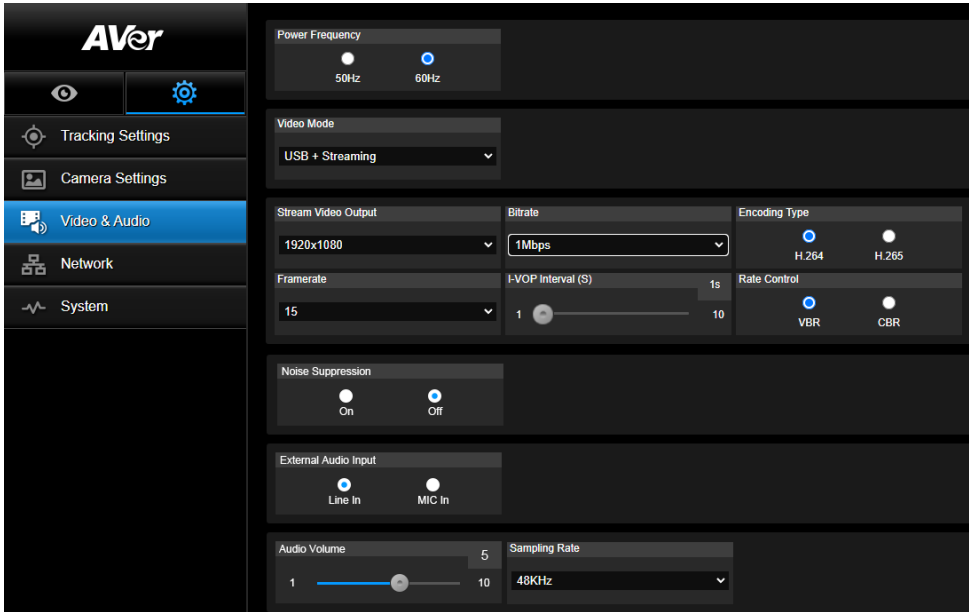

3 types of video modes can be selected and each one only supports single function,

- **Stream Only:** Supports RTSP/RTMP only.
- **USB Only** (factory default): Supports USB port output only; not compatible with AVer PTZ Management and PTZ Control Panel. Please switch to the other two modes if necessary.
- **USB + Streaming:** Supports both RTSP/RTMP and USB output at the same time.

**[Note]** If Video mode is in "Stream Only", the frame rate is up to 60fps; in "USB + Streaming" mode, the frame rate is up to 30fps.

- **Noise Suppression:** For the built-in microphone, you can enable **Noise Suppression**. The built-in microphone will then suppress all background sounds that isn't speech.
- **External Audio Input:** You can select **Line In** or **MIC In**.

## Network

Set up IP address of camera – DHCP or static IP, Hostname, Netmask, Gateway, and DNS. After setting, select “**Confirm**” to apply settings.

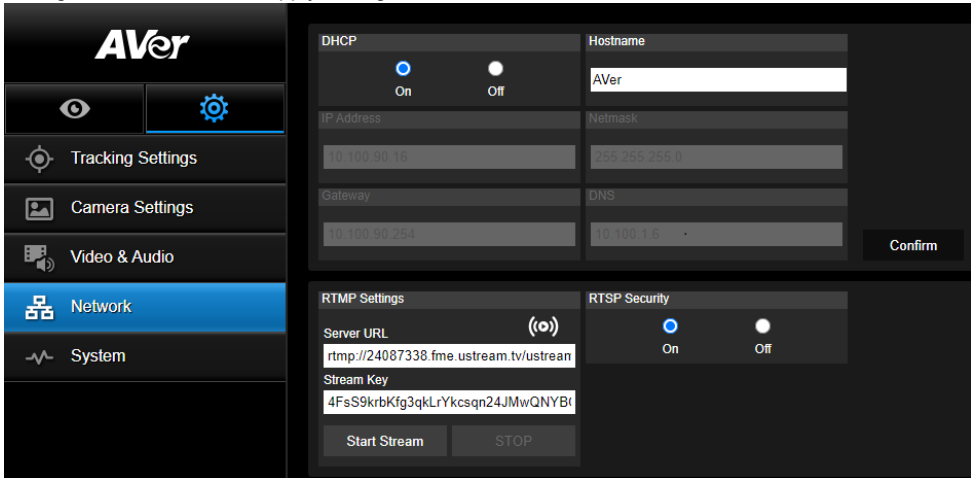

## RTMP Settings

Follow below steps to set up RTMP:

1. Get the RTMP server URL and stream key from the broadcasting platform and enter in “**Server URL**” and “**Stream Key**” column.
2. Select “**Start Stream**” to begin uploading the live video of the camera to the broadcasting platform.
3. Select “**STOP**” to stop uploading the video.

**[Note]** To get the RTMP server URL and stream key, please refer to the instruction of broadcasting. RTSP Security for user to set a security key number for streaming.

## Connecting to DL10 via RTSP

On your media applications such as VLC, PotPlayer, or QuickTime, you can connect to DL10 by entering the following RTSP URL:

“[rtsp://IP address of DL10/live\\_st1](#)”.

For Example: [rtsp://192.168.1.168/live\\_st1](#)

You can enable/disable **RTSP Security** function.

(When RTSP Security is **On**, the RTSP stream ID and Password will be synchronized with those of DL10 Web user interface.)



## System

The system information of camera is displayed in this page, including Model Name, IP Address, Serial Number, MAC Address, and Firmware Version.

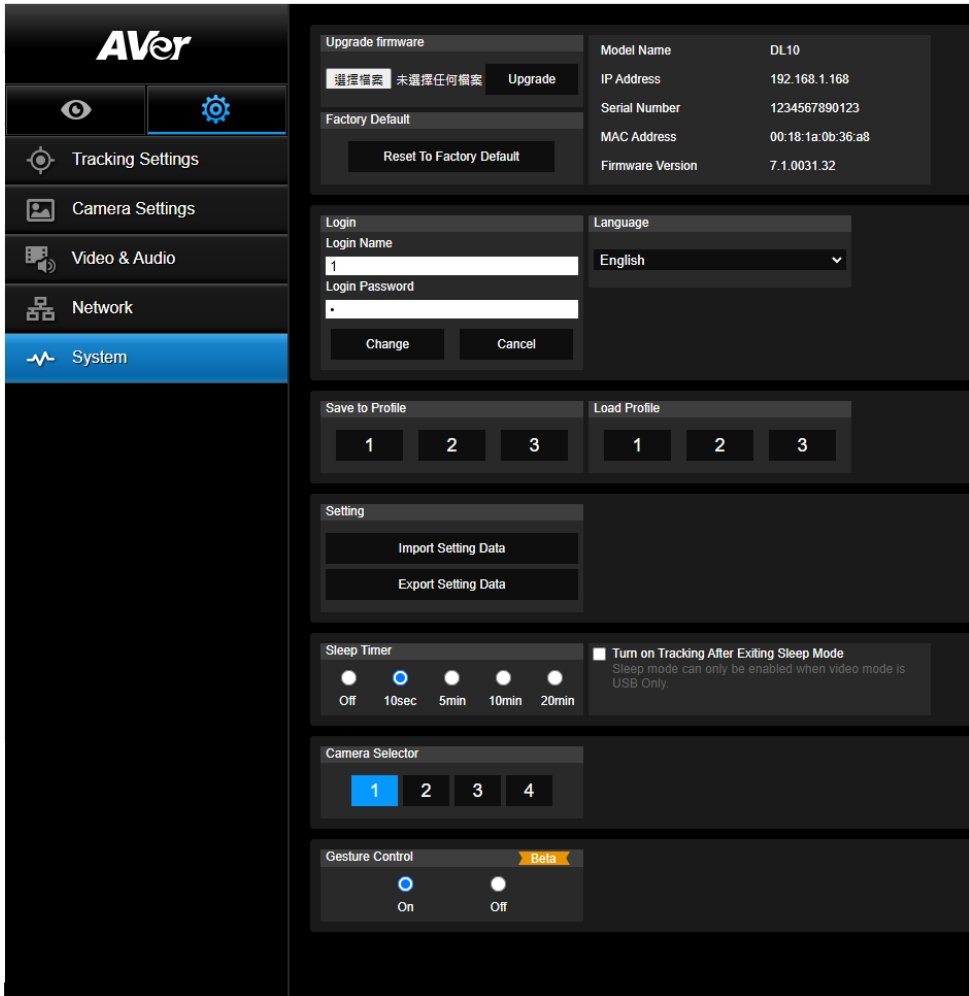

- **Upgrade firmware:** follows below steps to upgrade the firmware.
  1. Download the newest firmware from:  
Global: <https://www.aver.com/download-center>  
USA: <https://www.averusa.com/education/support>  
Europe: <https://www.avereurope.com/download-center>
  2. Connect to the camera through the browser.
  3. Select **System** > **Upgrade firmware** > **Choose File**.
  4. Select the firmware and select the “**Upgrade**” button.
  5. It takes about 5 minutes to finish update. After update, log in the web page again.

- **Factory Default:** clears all values and resets the camera back to factory default values.
- **Login:** the default login name and password are **admin/admin**. To change the login name and password, enter the new login name and password and select the “**Change**” button.
- **Language:** changes the Web UI language.
- **Save to Profile:** saves up to 3 different settings including preset settings values, tracking mode, and tracking setting values of camera.

**[Note]** The settings of profiles will be cleared after factory reset.

- **Load Profile:** loads up to 3 different settings of camera. After selecting Load Profile, camera will go back to Home position.
- **Setting:** You can select **Import Setting Data** or **Export Setting Data**.



**[Note]**

1. Importing the setting data with this procedure will overwrite all current data include camera password, IP address, value saved in Profile, etc.
2. Camera will restart once the setting data is complete.

- **Sleep Timer:** sets the duration of the sleep timer. When there is no UVC connection and timer is up, the camera will enter the sleep mode. You can select **Off** to disable the sleep mode. Check the box labeled **Tracking After Exiting Sleep Mode**, then camera tracking will be turned on automatically after exiting sleep mode regardless of previous tracking status.

**[Note]:** Before configuring the sleep mode, make sure you access **Video & Audio > Video Mode** and select **USB Only**.

- **Camera Selector:** selects a camera to operate.
- **Gesture Control:** By default, Gesture Control is **Off**. Click **On** and raise your hand up beside your face to show 0, 5, or 4 to control camera tracking. It is essential that the distance between you and the camera is within 5 meters and you gesture the number right beside your face for 3 to 4 seconds. Make sure your hand is clearly distinguished from a plain background with few objects and little furniture so that the camera can get a clear read of your hand.

	<p>Showing 0 turns off camera tracking.</p>
	<p>Showing 5 turns on camera tracking.</p>

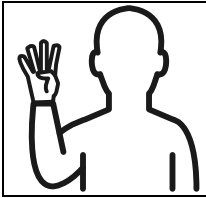

Showing 4 switches the camera's shooting angle between the presenter's **Full Body** and **Upper Body**.

## FAQ

1. Can I pan, tilt, zoom, and set preset point when tracking is on?
  - Yes, but tracking will be off when activating pan/tilt/zoom or go to preset point.
2. Any value will be auto saved and shifted when going to the preset point?
  - Yes, preset point value: PTZ, exposure, shutter, ev, brightness, gain, slow shutter, white balance, focus, focus position, digital zoom, R&B gain.
3. What value will be saved in profile?
  - Profile saving value: 1) preset setting values, 2) tracking mode, and 3) tracking setting values.
4. How to switch from Zone mode to Presenter mode?
  - You may switch to Presenter mode by simply pressing Upper or Full button on your remote control.
5. Where can I configure the Hybrid Mode?
  - You can access the camera Web user interface to configure the Hybrid Mode. The Hybrid Mode is not supported by the remote control.
6. What should I pay attention to when configuring the Effective Tracking Area under the Hybrid Mode?
  - Effective Tracking Area defines where the presenter is tracked. When configuring the Effective Tracking Area, include the preset point zone (Preset 10-13) as well.
7. Why can't I access the camera live view?

Instead of the camera live view, you might be seeing one of the following 2 pictures:



This picture indicates that the camera is in the privacy mode and you can exit the privacy mode by lightly pressing the power button on the remote control.



This picture indicates that the camera is in the sleep mode and you can wake the camera up by reconnecting to the UVC image of the camera. Or, you can go to **Video & Audio < Video Mode** and select **Stream Only** or **USB + Streaming** to wake the camera up.

8. How do I upgrade my firmware and what tools do you support?
- You will find the latest firmware version from the AVer official website:
    - Headquarters: <https://www.aver.com/download-center>
    - USA Branch office: <https://www.averusa.com/education/support>
    - Europe Branch office: <https://www.avereurope.com/download-center>

You can launch and upgrade the camera firmware via the camera webpage. In addition, we also provide an automatic and manual firmware update via AVer software, including AVer PTZ Management and AVer CaptureShare.

# Specification\*\*

Camera	
Image Sensor	1/2.8" CMOS
Effective Picture Elements	2 Megapixels
Output Resolutions	USB: 1080P60 (max) RTSP: 1080P60 (max)
Minimum Illumination	0.5 Lux (IRE50, F2.0, 30 FPS)
S/N Ratio	> 50dB
Gain	Auto, Manual
TV Line	800 (Center/Wide)
Shutter Speed	1/4 s to 1/10,000 s (60Hz) 1/3 s to 1/10,000 s (50Hz)
Exposure Control	Full Auto, Manual, WDR
White Balance	Auto, Manual
Optical Zoom	3X
Digital Zoom	2X
Viewing Angles	DFOV: 90° (Wide) to 35.8° (Tele)
	HFOV: 82° (Wide) to 31.7° (Tele)
	VFOV: 51° (Wide) to 17.9° (Tele)
Focal Length	f = 3.3 mm (Wide) to 9.7 mm (Tele)
Aperture (Iris)	F = 2.0 (Wide) to 3.7 (Tele)
Minimum Working Distance	0.5 m (Wide), 1.0 m (Tele)
Pan/Tilt Angles	Pan: ±170°, Tilt: ±90°
Pan/Tilt Speed (Manual)	Pan: 1° to 100°/sec, Tilt: 10.789° to 100°/sec
Preset Speed (Maximum)	Pan: 200°/sec, Tilt: 200°/sec
Preset Positions	10 (IR), 256 (IP & USB)
Camera Control - Interface	IP, USB
Camera Control - Protocol	VISCA (IP), CGI (IP), USB

Noise Reduction	2D/3D NR
Image Effect	Noise Reduction (2D/3D), Flip, Mirror, WDR
WDR	Yes
Power Frequency	50 Hz, 60 Hz
Noise Suppression	Yes
<b>AI Auto Tracking Functions</b>	
Tracking Modes	Presenter Mode, Zone Mode, Hybrid Mode
Gesture Control	Yes (Tracking On/Off, Full/Upper Body)
<b>Privacy Protection Mechanisms</b>	
Protection Modes	Privacy Mode, Sleep Mode
<b>Sleep Mode</b>	
Sleep Mode	Yes (Control by Web Page and CaptureShare)
<b>Audio</b>	
Channel	2ch, Mic in/Line in (Stereo), Built-in microphone (Mono)
Codec	AAC-LC (48/32/16/8K), PCM (48K)
Sample Rate	48/32/16/8 kHz
<b>Interface</b>	
Video Outputs	IP, USB
Audio Outputs	IP, USB
Audio Inputs	Mic in, Line in
Built-in Microphone	Yes
<b>Built-in Microphone</b>	
Built-in Microphone	2 (omnidirectional)
Noise Suppression	Yes
Pick-up Range	5 meter
Sensitivity	-33 dBFS
Frequency Response	30 Hz to 20,000 Hz

Maximum SPL	129 dB SPL at 0.5 meter
<b>General</b>	
Power Requirement	AC100 - 240V to DC12V 2A or above
Power Consumption	11W
PoE+	NA (LAN)
Dimensions (W x D x H)	92.39 mm x 94.44 mm x 164.00 mm
Net Weight	745 g
Application	Indoor
Tally	NA
Security	Kensington lock
Operating Conditions	Temperature: 0°C to +40°C Humidity: 20% to 80%
Storage Conditions	Temperature: -20°C to +60°C Humidity: 20% to 95%
<b>IP Streaming</b>	
Resolution	1080P (60FPS)
Video Compression	H.264, MJPEG
Audio Compression	AAC
Maximum Frame Rate	60FPS
Bit-rate Control Modes	VBR/CBR
Range of Bit-rate Setting	512 Kbps to 32 Mbps
Network Interface	10/100 Base-T
Multi-stream Capability	2
	(RTSP/Web Page), 1080P60FPS (max)
	(Web Page/UVC), 1080P60FPS (max)
	3
	(RTSP/Web Page/UVC), 1080P30FPS (max)
Network Protocols	IPv6, IPv4, TCP, UDP, ARP, ICMP, IGMP, HTTP, DHCP, RTP/RTCP, RTSP, RTMP, VISCA over IP



NDI®   HX Capability	NA
<b>USB</b>	
Connector	USB 3.1 Gen 1 Type-B, backward compatible with USB 2.0
Video Format	MJPEG/YUY2
Maximum Video Resolution	1080P60
USB Video Class (UVC)	UVC 1.1
USB Audio Class (UAC)	UAC 1.0
<b>Web UI</b>	
Live Video Preview	Yes
Camera PTZ Control	Pan, Tilt, Zoom, Focus, Preset Control
Camera/Image Adjustment	Exposure/White Balance/Picture
Network Configuration	DHCP, IP Address, Gateway, Subnet mask, DNS
<b>Software Tools</b>	
Single Camera Control	AVer CaptureShare (via USB, via IP with virtual camera) AVer PTZ Control Panel (via IP) AVer OBS Plugin for PTZ Cameras (via IP)
Multi-Camera Control and Configuration	AVer PTZ Management (via IP)
Device IP Searching	AVer CaptureShare/Information AVer PTZ Control Panel/Auto Search AVer PTZ Management/Setup/Device/Add/Auto Search
<b>Warranty</b>	
Camera	3 Years
Accessories	1 Year

\*For further controls and configurations of the software mentioned above, please refer to the specific software and its user manual on our Download Center (non-USA) or Support site (USA).

\*\*Specifications are subject to change without prior notice.