



LF-2060 X
Cod. **02011317** EAN **8422248105231**



- Mechanical control panel
- 3 extraction levels
- Extraction power (according to UNE/EN 61591): 195m3/h - 107m3/h
- Motor maximum airflow free outlet: 350m3/h
- Sound power (Reg.(EU) n°65/2014): 56dB(A), maximum: 68dB(A)
- Tangential motor. Extra silent. Maximum energy consumption 65W
- E-14 LED lighting
- Easy-to-install system
- Dishwasher-washable filters
- Finished in stainless steel
- Max. pressure 325 Pa
- 120mm outlet diameter
- Energy Class: C

► **Accesorios (not included)**

Active charcoal filterCod. 02846764 / EAN 8422248078276

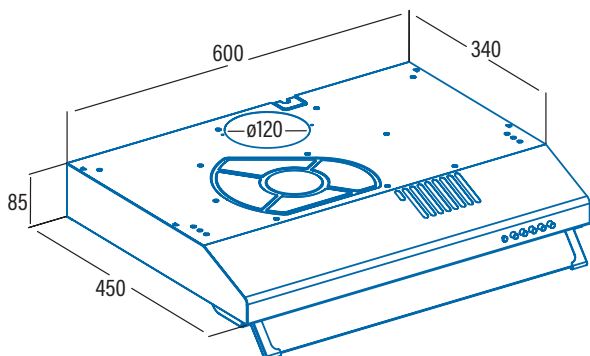

Code	02011317
EAN	8422248105231
Model	LF-2060 X
Type	Standard
"Product fiche according to directives EU65/2014 - EN61591, EN60704-2-13, EN50564"	
AEC (Annual Energy consumption) (kWh/annum)	45,1
EEL class (Energy Efficiency Class)	C
FDE (Fluid Dynamic Efficiency)	9,4
FDE class (Fluid Dynamic Efficiency Class)	E
LE (Lighting Efficiency) (lux/W)	14,5
LE class (Lighting Efficiency Class)	D
GFE (Grease Filtering Efficiency)	79,6
GFE Class (Grease Filtering Efficiency class)	C
Air flow at minimum speed (m3/h)	107,5
Air flow at maximum speed (m3/h)	195,6
Air flow at intensive speed (TURBO) (m3/h)	-
Sound Power Level at minimum speed (dB)	56
Sound Power Level at maximum speed (dB)	69
Sound Power Level at intensive speed (TURBO) (dB)	-
Po (Power Consumption in off mode) (W)	0
Ps (Power Consumption in standby) (W)	0
Integration directive EU 66/2014	
f (Time Increase Factor)	1,7
EEL (Energy Efficiency Index)	82,4
QBEP (Flow Rate at Best Efficiency Point) (m3/h)	116,2
PBEP (Static Pressure Difference at Best Efficiency Point) (Pa)	192
WBEP (Electric Power Input at Best Efficiency Point) (W)	66,2
WL (Nominal Power Consumption of Lighting system) (W)	5,5
EMIDDLE (Average Illumination of Lighting system on Cooking surface) (lux)	80
External Dimensions	
Width (mm)	600
Depth (mm)	452
Total max height(mm)	85
Total min height(mm)	85
Outlet Diameter (mm)	120
Characteristics	
Motor	LIN
Extraction Levels	3
Motor Maximum Power Consumption	65
Maximum Pressure	325
Intensive Speed (TURBO) Pressure	-
Control Type	Mechanic
Automatic shut-down timer	-
Electronic Filter Saturation Indicator	-
Filter Type	Metallic
Anti-grease Filter Number	2
Inner Shield	-
Lighting	
Light Type	LED E-14
Adjustable Intensity Lighting	-
N° of Lamps	1
Installation	
Minimum height distance to a electric worktop hob (mm)	550
Minimum height distance to a gas worktop hob (mm)	650
Installation with Outlet tube to the exterior / Recirculating	BOTH
Easy Installation System	√
Electric Connection	
Total Rush Power (W)	65,5
Rated Voltage (V)	220-240
Network Frequency (Hz)	50
Electrical Insulation Class	CLASS I
Plug	-
Accessories	
Upper Decorative tube Extension	-
White Decorative Tube	-
Black Decorative Tube	-
Island Tube Enhancer	-
Check Valve	02849002
MAX PRO Metal Filter	-
Metal Filter	02833170
DUAL Filter (metal + active charcoal)	-
Active Charcoal Filter	02846764
Noiseless Flexible Duct	-