



EN ■ Electric oven

Translation of the original manual

READ CAREFULLY AND STORE FOR FUTURE USE.**General warnings**

- This appliance may be used by children 8 years of age and older and by persons with physical or mental impairments or by inexperienced persons, if they are properly supervised or have been informed about how to use the appliance in a safe manner and understand the potential dangers.
- Children must not play with the appliance. Cleaning and maintenance performed by the user must not be performed by unsupervised children.
- Children younger than 8 years of age must be kept away from the appliance and its power cord.
- In the event that the power cord is damaged, have it repaired at a professional service centre to prevent causing a dangerous situation. It is forbidden to use the appliance if it has a damaged power cord.

Electrical safety

- Before connecting this appliance to a power socket, make sure that the voltage stated on its rating label corresponds to the voltage in your power socket.
- Connect the appliance only to a properly grounded socket. Do not use an extension cord.
- Ensure that the power plug contacts do not come into contact with water or any other liquid. If precisely this happens, carefully dry the power plug before using it again.
- Do not place heavy items on the power cord. Make sure the power cord does not hang over the edge of a table and that it is not touching a hot surface or sharp objects.
- Do not fasten the power cord between the oven door and the frame and do not lead it along hot surfaces. The insulation on the power cord could melt and subsequent short circuiting will lead to a fire.
- The electrical circuit to which the appliance is connected must be equipped with a circuit breaker rated for the draw of electrical current of this appliance. Do not start any other appliance at the same time that could result in the overloading of the electrical circuit and trigger the circuit breaker.
- Do not disconnect the appliance from the power socket by pulling on the power cord. This could damage the power cord or the power socket. Disconnect the power cord from the power socket by pulling on the plug.
- Do not connect and disconnect the power cord to and from the power socket with wet hands.
- To avoid the danger of injury by electrical shock, do not repair the appliance yourself or make any adjustments to it. The appliance does not contain any components repairable by the user. Have all repairs or adjustments of the appliance performed at an authorised service centre. Tampering with the appliance during the warranty period may void the warranty.
- To prevent the risk of injury by electrical shock, never submerge the appliance and its power cord in water or any other liquid, or wash these parts under running water.
- In the event that the appliance falls into water, under no condition reach for it, rather, immediately disconnect the power cord from the power socket. Never use an appliance that has been submerged in water. Hand it over to an authorised service centre for inspection.
- Always turn off the appliance and disconnect it from the power socket when you have finished using it.

Safety during use

- This appliance is designed only for household use and constructed solely for heating a standard amount of food in the household. Do not use this appliance for commercial, industrial or laboratory purposes. Also, do not use it for heating the room it is in, for drying laundry, etc.
- This appliance is not designed to be built-in. It is intended for use in open areas. The appliance must be located on a kitchen countertop or a table so that its rear side faces the wall.
- This appliance is not intended to be operated using an external timer switch or a remote control system that would enable this appliance to be turned on automatically.
- Use the appliance and its accessories in accordance with the instructions contained in this user's manual.

- Only use the appliance with the original accessories that came with it.
- Before every use, check the selected accessory for damage. Never use the appliance with a damaged accessory.
- Do not place the appliance or its accessories on an electric or gas stove or in its vicinity, on the edge of a table or on an unstable surface. Only place the appliance on an even, dry and stable surface.
- Do not expose the appliance and its accessories to the outdoor environment, extreme temperatures, direct sunlight, excessive humidity or excessively dusty environments.
- Do not place the appliance and its accessories near heaters, open fires or other sources of heat.
- Do not place any items on to the appliance and do not step or sit on it.
- Protect the appliance against being dropped on the floor or table, even from low heights and against items falling on it.
- If the appliance is used in the vicinity of children, be especially careful and select an operating location that is out of their reach.
- The temperature of adjacent surfaces may be higher when the appliance is in operation. The appliance may only be located on a surface that is resistant to higher temperatures. Never place aluminium foil underneath the appliance to protect the surface on which it is located. Do not place aluminium foil between the heating elements and do not allow it to touch the walls inside the appliance, otherwise the appliance may overheat.
- Do not use the appliance if it has fallen on the floor, if it was submerged in water, if it is not functioning correctly or if it is damaged in any other way.
- Do not cover or otherwise block the vents of the appliance. Take care to prevent liquids or foreign objects from entering into them.



Attention:

Hot surface! When the appliance is in operation, the door and the exterior surface of the appliance is hot.

- The appliance heats up significantly during operation. Never touch the hot surfaces or heating elements in the baking chamber of the oven. Prevent children or pets from accessing the appliance while it is in operation. Always slide hot accessories and cooking or baking containers in and out of the baking chamber using the supplied handles and kitchen gloves.
- Do not use the top surface of the appliance as a shelf for placing food or other items. Do not use the inside of the appliance for storing food.
- Make sure that the heated surface of the glass door does not come into contact with cold water as this could result in it cracking.
- In the event that you notice smoke, immediately turn off the oven and disconnect the power plug from the socket. Leave the oven door closed to prevent potential fire from spreading.
- Due to residual heat, the accessible surfaces of the appliance remain hot after it is turned off. Do not touch the hot surface. This could cause skin burns. Use the handle to open and close the oven door. When handling the appliance and its accessories (trays, racks, etc.) proceed carefully after use as they may be hot!
- When handling hot cookware, which contains hot food or liquids, be especially careful so as not to burn or scald yourself. Put hot accessories and cookware aside only on to stable heat resistant surfaces.
- Do not perform any maintenance on the appliance other than cleaning the individual components as described in chapter Cleaning and maintenance.
- Always turn off the appliance and disconnect it from the power socket if you will not be using it and if you will be leaving it without supervision, before assembly, disassembly, cleaning or moving it.
- Keep the accessories (trays, racks, etc.) clean because they come into contact with food.
- The surfaces of the appliance or its accessories that come into contact with food must always be cleaned according to the instructions in this user's manual.
- Store the appliance in a dry environment.
- Do not place any paper or plastic items inside the appliance. Do not store anything inside the appliance.

A

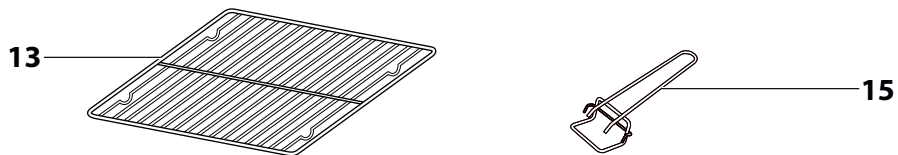
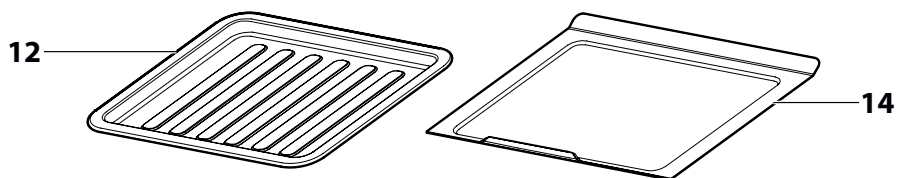
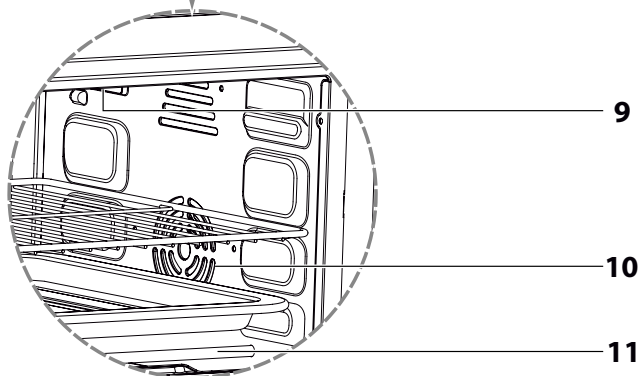
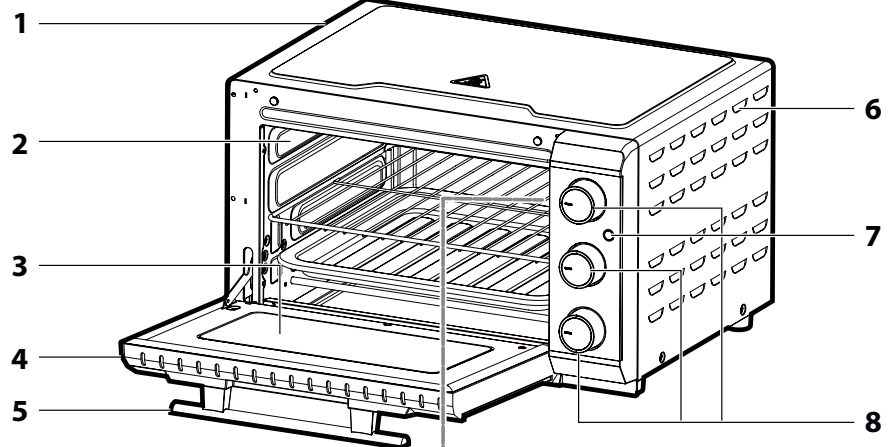

B

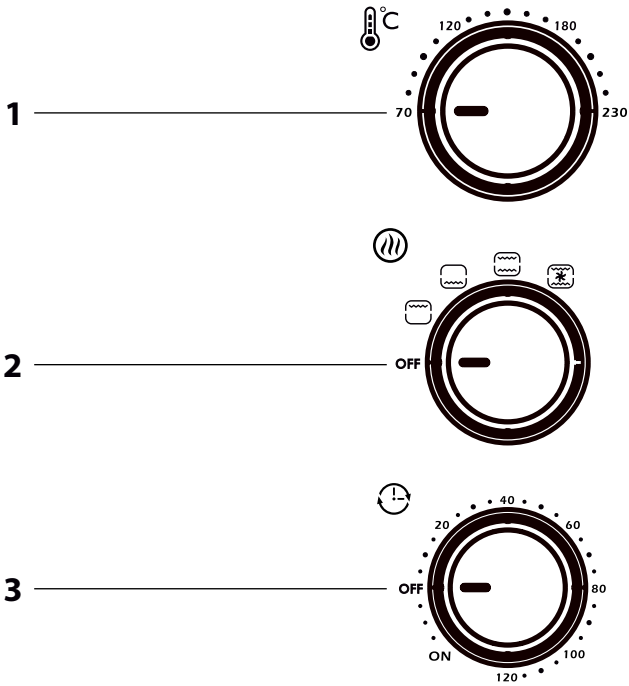

C

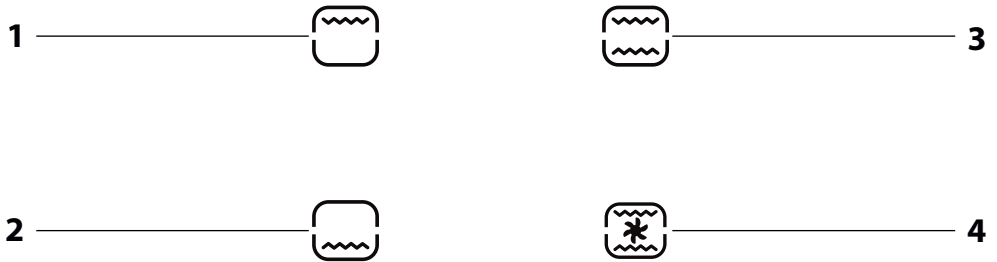

D

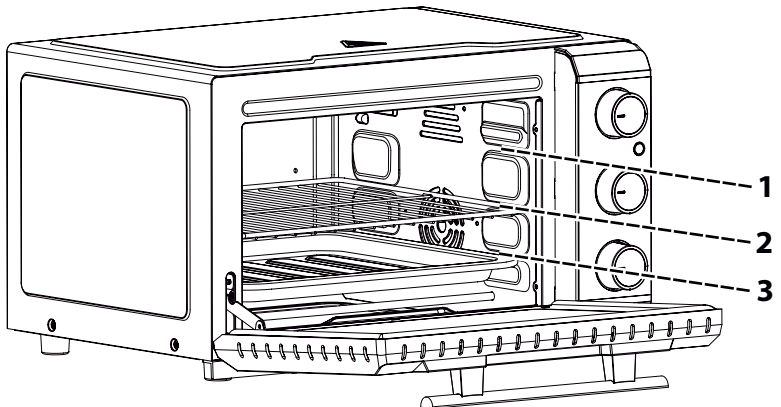

EN Electric oven

User's manual

- Prior to using this appliance, please read the user's manual thoroughly, even in cases, when one has already familiarised themselves with previous use of similar types of appliances. Only use the appliance in the manner described in this user's manual. Keep this user's manual in a safe place where it can be easily retrieved for future use. In the event that you hand this appliance over to somebody else, make sure to also include this user's manual.
- We recommend saving the original cardboard box, packaging material, purchase receipt and responsibility statement of the vendor or warranty card for at least the duration of the legal liability for unsatisfactory performance or quality. In the event of transportation, we recommend that you pack the appliance in the original box from the manufacturer.
- Carefully unpack the appliance and take care not to throw away any part of the packaging before you find all the parts of the appliance.

DESCRIPTION OF THE APPLIANCE AND ACCESSORIES

A1 Body of the oven	A6 Side panels with vents
A2 Side tabs creating grooves for insertion of a baking tray or rack into the baking chamber of the oven The tabs form a total of three grooves above each other, which enable the placement of the baking tray or rack at various heights	A7 Operation indicator
A3 Double-glazed window	A8 Control elements
A4 Door	A9 Light
A5 Handle	A10 Fan
	A11 Heating elements
	A12 Baking tray
	A13 Grilling rack
	A14 Drip tray
	A15 Holder for removing the rack or baking tray
B1 Temperature control knob	B3 Time control knob
B2 Baking mode knob	
C1 Top heat Suitable for toasting and grilling	C3 Top and bottom heat Suitable for baking
C2 Bottom heat Suitable for heating ready meals	C4 Convection baking with running fan

PURPOSE OF USE AND APPLIANCE FEATURES

- This electric oven is intended to be used as a stand-alone appliance and is an equivalent replacement for a standard built-in oven that requires more space. Its significant advantage, apart from its compact dimensions, is also its power efficiency compared to standard ovens.
- The electric oven is intended for baking a standard amount of food in the household. It can be used for baking, grilling, crisping and many other tasks that are used in the household for preparing meals.

BEFORE FIRST USE

- Before using it, wash all removable parts that come into contact with food in hot water using a small amount of kitchen detergent, then rinse with clean water and wipe dry.
- Wipe the outer surface of the oven using a soft sponge dipped in warm water with a small amount of kitchen detergent and wipe it dry.
- Also clean out the baking chamber of the oven using a lightly dampened wiping cloth and then wipe everything dry. When cleaning, take care not to wet the heating elements or the fan. Never submerge the oven in water or any other liquid.
- In order for the oven to remove any odours from the manufacturing process, locate it in a position according to the chapter OPERATING LOCATION OF THE OVEN, start it empty for 15 minutes in the top and bottom heat combination mode **C3** with the temperature knob **B3** set to the highest temperature. Before turning it on, make sure that no packaging materials remain in the baking chamber of the oven.
- Allow the oven to cool down after it is turned off.



Note:

When this oven is turned on for the first time, fumes may be emitted for the first 5 to 15 minutes. This is the result of the protective coatings on the heating elements being burned off. This is normal and does not negatively impact the performance of the oven and the fumes will disperse with use.

OPERATION

OPERATING LOCATION OF THE OVEN

- Locate the oven in a well-ventilated, warm and dry room with minimal dustiness. To ensure proper air circulation, there must be a clearance of at least 12 cm along the sides and 30 cm above the oven.
- The surface on which the oven is placed must be stable, heat resistant and sufficiently far from other sources of heat. The load bearing capacity of the selected surface must correspond to the combined weight of the oven and its contents.
- Also select a location respecting the fact that it is not appropriate to move the oven while it is running and that fumes are released from the food.

USING THE ACCESSORIES

- **Baking tray A12:** Suitable for baked goods, cakes, confectionery, frozen food, large roasts, foods with a high liquid content, etc.
- **Grilling rack A13:** Suitable for grilling or roasting meals, baking in cookware, toasting, for cake pans, soufflés or deep-frozen meals, etc.
- **Drip tray A14:** Serves to catch crumbs, fat drippings and other juices released during grilling or roasting. It protects the heating elements and the baking chamber against soiling.
- **Holder A15:** Enables the safe handling of the hot baking tray or grill rack.

INSERTING AND REMOVING ACCESSORIES

- The baking chamber of the oven has three levels for inserting accessories. Each level comprises of two guide grooves (see fig. D), which enable the tray or rack to be inserted or removed.

Position 1: Top position. It is used for grilling the majority of meats. Remember to leave sufficient amount of free space above the food since the food may increase in volume when heated.

Position 2: Middle position. Ideal for the majority of baking and cooking, including baking of pizza, warming up and standard cooking and baking with hot air. Suitable for grilling certain taller meals.

Position 3: Bottom position. Provides sufficient height for baking taller meals. Use this position for baking, re-heating or heating, etc.

- Always insert the accessories between the guiding grooves at the same level and also always insert them fully into the baking chamber so that they are not touching the oven door.
- Place the drip tray on the very bottom of the baking chamber.
- To slide hot accessories in or out for the purpose of checking the food during operation or for removing the accessories completely, one can use the supplied holder **A15**. Nevertheless, always also use kitchen gloves.



Attention:

If you wish to slide an accessory out only partially during operation, pull it out by no more than one half of its length, otherwise it could tilt out.

- Accessories that are not used during operation must be taken out of the oven.

USING THE CONVECTION BAKING MODE WITH FAN

- Using the fan during baking is suitable namely for baking doughs and meats, it is also appropriate for grilling meat, fish and vegetables. The fan is also used to speed up the defrosting of meat products or vegetables from the freezer.
- The fan quickly and evenly distributes hot air inside the oven. Thanks to this, the food is exposed to the effects of evenly distributed heat from all sides.
- Activate the fan by turning the knob to position **C4**.



Note:

When using the fan for baking, it may speed up the meal preparation time by up to 30%. Therefore, check the food being prepared more frequently and sooner than usual to avoid burning it.

The time required for defrosting food depends on its weight, therefore, the defrosting process needs to be regularly monitored.

BAKING TIPS



Attention:

Do not place excessively large food pieces into the oven. The food must not touch the sides of the baking chamber or the heating elements, otherwise, there is a danger of fire or injury by electrical shock.

Do not heat liquids and meals in enclosed tin cans or canning jars or in plastic containers. Always only use cookware that is suitable for electric ovens.

- Take care that the heating elements are not soiled while baking/grilling, for example by juices or fat from food, and for this reason always use the supplied drip tray.
- Regularly inspect the food while baking it and adjust the baking time as necessary. When preparing ready-made meals, follow the instructions on the packaging of the food. After 3/4 of the recommended baking time has elapsed, check the meal and if necessary, adjust the time and temperature.
- If you will be baking various types of food after each other (e.g. meat, fish, fruit), we recommend that you clean the remains from the baking tray/rack between the individual courses. Do not slice the food while it is on the baking tray or rack.
- The recommended baking times for foods recommended in most recipes or cookbooks assume that meat has the temperature as when taken from the refrigerator. Baking frozen meat may take significantly longer. Therefore, we recommend using a food thermometer. The baking time may be adjusted according to your habits and experience. The longer that you cook the food, the more well-done and crispier it will be.

GRILLING TIPS

- Cut the food you wish to grill into small thin slices. Trim away any excess fat from the meat and attempt to remove excess moisture from the food before grilling.
- You may marinate, season, coat with sauce or oil in advance or also use aluminium foil. Prevent any soiling of the bottom of the oven by dripping juices by inserting the drip tray or the baking tray. If you pour some water into the tray in advance, you will create a tasty gravy juice.

- For stewing and for smaller food pieces, place the rack into position 2 (fig.).
- Before grilling vegetables, fish or lean meat, we recommend that you grease the baking tray or rack with vegetable oil or spray it with a special spray that prevents foods from sticking.
- When you have finished grilling and before grilling again, it is recommended to remove any fat and grease from the drip tray. Hot fat may smoke.



Attention:

Do not touch the front side of the door while baking or grilling since the glass may become very hot. Pay special care to ensure that children do not touch the door!



Note:

When the oven is used, occasionally cracking sounds will be made due to material expanding and contracting. This event is completely normal and it is not a reason for complaint.

TURNING ON AND STARTING BAKING

- Place the oven in a suitable location according to chapter OPERATING LOCATION OF THE OVEN
- Insert the baking tray or the rack with the prepared food into the oven according to the chapter INSERTING AND REMOVING ACCESSORIES and properly close the oven door.
- Connect the power cord plug to a power socket. The operating indicator **A7** will be lit.
- Use the temperature control knob **B1** to set the desired temperature in the range 70-230 °C.
- Use knob **B2** to select one of the baking modes.
- Use knob **B3** to set the desired baking time. This will start the oven.



Note:

Setting the time control knob to the ON position, will leave the oven turned on permanently until the knob is set to the OFF position.

FINISHING BAKING

- At the end of the set time the oven will beep.
- Open the door and using kitchen gloves and the supplied holders, take the baking tray or rack or cookware with the food out of the oven.

ENDING OPERATION

- When you have finished using the oven, always set the baking mode knob **B2** and the temperature control knob **B3** to the OFF position.
- Disconnect the power cord from the power socket.
- Allow the oven to cool down and then clean it according to the instructions in chapter CLEANING AND MAINTENANCE.



Attention:

When removing meals from the oven, be especially careful – the baking chamber of the oven and accessories will be very hot and there is a risk of serious burns.

CLEANING AND MAINTENANCE



Attention:

Prior to any cleaning or maintenance, always disconnect the oven from the power supply and allow the surfaces of the oven to cool down completely.

- Wipe the outer surface of the oven using a soft sponge dipped in warm water with a small amount of kitchen detergent and wipe it dry.
- Also clean out the baking chamber of the oven using a lightly dampened wiping cloth and then wipe everything dry. When cleaning, take care not to wet the heating elements or the fan. Never submerge the oven in water or any other liquid.
- Clean away food remains from any of the accessories that were used and then wash them in hot water using a small amount of kitchen detergent, then rinse with clean water and wipe dry.



Attention:

The oven and its power cord are not intended for washing in a dishwasher, in a kitchen sink, in a bathtub or in other containers. Do not spray these parts with water or any other liquid or submerge them in water or any another liquid. Never use chemicals, dishwashing wool, steel wool or cleaning agents with an abrasive component since these may seriously damage the surface of the oven.

- The vents of the oven must be unconditionally clean and enable air to pass through them. In the event that a vent becomes dirty or clogged with dust, clean it using a brush or vacuum out the dirt with a vacuum cleaner.

REPLACING THE LIGHT BULB



Warning:

Prior to replacing the light bulb in the baking chamber, the oven must be completely cooled down and disconnected from the power supply.

- The light in the baking chamber is found in the top right corner. To replace the light bulb, first screw out its glass cover and then screw out the light bulb itself.
- Screw in a new light bulb having the same parameters and reinstall the glass cover.

STORAGE

- Before storing it, the appliance must be completely cool, turned off and disconnected from the power supply and cleaned. The individual accessories must be clean.
- Store the appliance and its accessories in a clean, dry place out of children's reach. Keep the stored appliance and its accessories away from extreme temperatures, direct sunlight and excessive humidity and do not store it in an overly dusty environment.
- If storage space permits, we recommend storing the oven with the door ajar in order to prevent undesirable odours forming inside.

TECHNICAL SPECIFICATIONS

Rated voltage range	220–240 V AC
Rated frequency.....	50/60 Hz
Power output	1,350-1,650 W
Temperature range	70-230 °C
Time range.....	0-120 min
Capacity of the baking chamber	20 l
Dimensions.....	446 x 385 x 266 mm
Weight.....	7.5 kg
Electrical shock protection class.....	I
Noise level	<60 dB(A)

The declared noise emission level is lower than <60 dB(A), which represents a level A of sound power with respect to a reference sound power of 1 pW.

Explanation of technical terminology

Safety class for electrical shock protection:
Class I – Electrical shock protection is provided by basic insulation.

Changes to text and technical parameters are reserved.

INSTRUCTIONS AND INFORMATION REGARDING THE DISPOSAL OF USED PACKAGING MATERIALS

Dispose of used packaging material at a site designated for waste in your municipality.

DISPOSAL OF USED ELECTRICAL AND ELECTRONIC EQUIPMENT



This symbol on products or original documents means that used electric or electronic products must not be added to ordinary municipal waste. For proper disposal, renewal and recycling, hand these products over to determined collection points. Alternatively, in some European Union states or other European countries you may return your appliances to the local retailer when buying an equivalent new appliance.

Correct disposal of this product helps save valuable natural resources and prevents potential negative effects on the environment and human health, which could result from improper waste disposal. Ask your local authorities or collection facility for more details.

In accordance with national regulations penalties may be imposed for the incorrect disposal of this type of waste.

For business entities in European Union states

If you want to dispose of electric or electronic equipment, ask your retailer or supplier for the necessary information.

Disposal in other countries outside the European Union.

This symbol is valid in the European Union. If you wish to dispose of this product, request the necessary information about the correct disposal method from the local council or from your retailer.



This product meets all the basic requirements of EU directives related to it.