

SAMSUNG

User Manual



Figures and illustrations in this User Manual are provided for reference only and may differ from actual product appearance

AH81-16773R-00
NSPBI01462A-00

HW-Q990C



You can access the FULL MANUAL on Samsung's on-line customer support centre by scanning the QR code on the left.
To see the manual on your PC or mobile device, download the manual in document format from Samsung's website. (<http://www.samsung.com/support>)

© 2023 Samsung Electronics Co., Ltd. All rights reserved.
Contact **SAMSUNG WORLDWIDE**

If you have any questions or comments relating to Samsung products, please contact the SAMSUNG customer care Centre.

Country	Samsung Service Centre	Web Site
UK	0333 000 0333	www.samsung.com/uk/support
IRELAND (EIRE)	0818 717100	www.samsung.com/ie/support
GERMANY	06196 77 555 77	www.samsung.com/de/support
FRANCE	01 48 63 00 00	www.samsung.com/fr/support
ITALIA	800-SAMSUNG (800.7267864)	www.samsung.com/it/support
SPAIN	91 175 00 15	www.samsung.com/es/support
PORTUGAL	210 608 098 Chamada para a rede fixa nacional Dias úteis das 9h às 20h	www.samsung.com/pt/support
LUXEMBURG	261 03 710	www.samsung.com/be_fr/support
NETHERLANDS	088 90 90 100	www.samsung.com/nl/support
BELGIUM	02-201-24-18	www.samsung.com/be_fr/support (Dutch) www.samsung.com/be_fr/support (French)
NORWAY	21629099	www.samsung.com/no/support
DENMARK	707 019 70	www.samsung.com/dk/support
FINLAND	030-6227 515	www.samsung.com/fi/support
SWEDEN	0771-400 300	www.samsung.com/se/support
POLAND	801-172-678* lub +48 22 607-93-33* * (opłata według taryfy operatora)	http://www.samsung.com/pl/support/
HUNGARY	0680SAMSUNG (0680-726-7864)	www.samsung.com/hu/support
AUSTRIA	0800 72 67 864 (0800-SAMSUNG)	www.samsung.com/at/support
SWITZERLAND	0800 726 786	www.samsung.com/ch/support (German) www.samsung.com/ch_fr/support (French)

Country	Samsung Service Centre	Web Site
CZECH	800 - SAMSUNG (800-726786)	www.samsung.com/cz/support
SLOVAKIA	0800 - SAMSUNG (0800-726 786)	www.samsung.com/sk/support
CROATIA	072 726 786	www.samsung.com/hr/support
BOSNIA	055 233 999	www.samsung.com/ba/support
North Macedonia	023 207 777	www.samsung.com/mk/support
MONTENEGRO	020 405 888	www.samsung.com/support
SLOVENIA	080 697 267 (brezplačna številka)	www.samsung.com/si/support
SERBIA	011 321 6899	www.samsung.com/rs/support
Kosovo	038 40 30 90	www.samsung.com/support
ALBANIA	045 620 202	www.samsung.com/al/support
BULGARIA	0800 111 31 - Безплатен за всички оператори *3000 - Цена на един градски разговор или според тарифата на мобилният оператор 09:00 до 18:00 - Понеделник до Петък	www.samsung.com/bg/support
ROMANIA	0800872678 - Apel gratuit *8000 - Apel tarifat în rețea Program Call Center Luni - Vineri: 9 AM - 6 PM	www.samsung.com/ro/support
CYPRUS	8009 4000 only from landline, toll free	www.samsung.com/gr/support
GREECE	80111-SAMSUNG (80111 726 7864) only from land line (+30 210 6897691 from mobile and land line)	www.samsung.com/gr/support
LITHUANIA	8-800-77777	www.samsung.com/lt/support
LATVIA	8000-7267	www.samsung.com/lv/support
ESTONIA	800-7267	www.samsung.com/ee/support

- Protect the product from moisture (i.e. vases), and excess heat (e.g. a fireplace) or equipment creating strong magnetic or electric fields. Unplug the power cable from the AC wall socket if the unit malfunctions. Your product is not intended for industrial use. It is for personal use only. Condensation may occur if your product has been stored in cold temperatures. If transporting the unit during the winter, wait approximately 2 hours until the unit has reached room temperature before using.
- The battery used with this product contains chemicals that are harmful to the environment. Do not dispose of the battery in the general household trash. Do not expose the battery to excess heat, direct sunlight, or fire. Do not short circuit, disassemble, or overheat the battery. CAUTION: Danger of explosion if the battery is replaced incorrectly. Replace only with the same or equivalent type.

01 CHECKING THE COMPONENTS

Soundbar Main Unit / Soundbar Remote Control / Batteries / Subwoofer / Surround Speaker x2 / Power Cord X 4 (Subwoofer, Surround Speaker, Soundbar) / Wall Mount Guide / Holder-Screw X 2 / Screw (M4 x L10) X 2 / Bracket-Wall Mount X 2 / Rubber-Foot X 4

NOTE

- For more information about the power supply and power consumption, refer to the label attached to the product. (Label: Rear of the Soundbar Main Unit)
- To purchase additional components or optional cables, contact a Samsung Service Centre or Samsung Customer Care.

02 PRODUCT OVERVIEW

Top Panel of the Soundbar

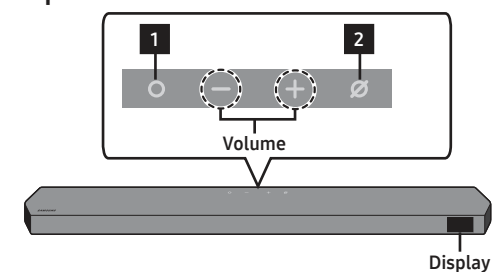

- (Multi Function) Button**
In standby mode, press the **(Multi Function)** button to turn on the Soundbar. Press the **(Multi Function)** button to change the input source.
- (Mic On/Off) Button**
Press the button to turn the microphone on or off. When the microphone is off, the LED indicator will glow red.

Bottom Panel of the Soundbar

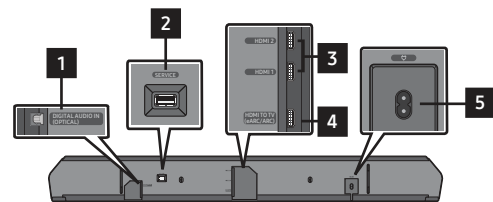

- DIGITAL AUDIO IN (OPTICAL)**
Connect to the digital (optical) output of an external device.
- SERVICE**
Connect a USB storage device to upgrade the product's software.
- HDMI 1 / HDMI 2**
Inputs digital video and audio signals simultaneously using an HDMI cable. Connect to the HDMI output of an external device.
- HDMI TO TV (eARC/ARC)**
Connect to the HDMI jack on a TV.
- POWER**
Connect the Soundbar's AC power cable.

03 CONNECTING THE SOUNDBAR

Connecting the power and units

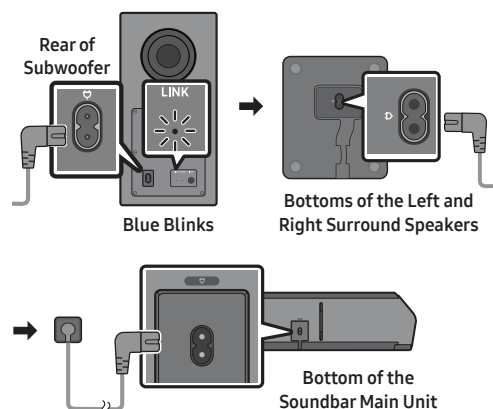

- The LINK LED indicator stops blinking and glows a solid blue when a connection is established between the Soundbar and the Subwoofer, surround speakers.

Using the Surround speaker mode

An optimal surround sound may be delivered depending on the position of the surround speaker. For more information, refer to the speaker section of the Full manual.

SAFETY INFORMATION

SAFETY WARNINGS

TO REDUCE THE RISK OF ELECTRIC SHOCK, DO NOT REMOVE THE COVER (OR BACK). NO USER-SERVICEABLE PARTS ARE INSIDE. REFER SERVICING TO QUALIFIED SERVICE PERSONNEL. Refer to the table below for an explanation of symbols which may be on your Samsung product.

CAUTION	
	RISK OF ELECTRIC SHOCK. DO NOT OPEN.
	This symbol indicates that high voltage is present inside. It is dangerous to make any kind of contact with any internal part of this product.
	This symbol indicates that this product has included important literature concerning operation and maintenance.
	Class II product: This symbol indicates that a safety connection to electrical earth (ground) is not required. If this symbol is not present on a product with a power cord, the product MUST have a reliable connection to protective earth (ground).
	AC voltage: Rated voltage marked with this symbol is AC voltage.
	DC voltage: Rated voltage marked with this symbol is DC voltage.
	Caution. Consult Instructions for use: This symbol instructs the user to consult the user manual for further safety related information.

WARNING

- To reduce the risk of fire or electric shock, do not expose this appliance to rain or moisture.

CAUTION

- TO PREVENT ELECTRIC SHOCK, MATCH WIDE BLADE OF PLUG TO WIDE SLOT, FULLY INSERT.
- This apparatus shall always be connected to a AC outlet with a protective grounding connection.
- To disconnect the apparatus from the mains, the plug must be pulled out from the mains socket, therefore the mains plug shall be readily operable.
- Do not expose this apparatus to dripping or splashing. Do not put objects filled with liquids, such as vases, on the apparatus.
- To turn this apparatus off completely, you must pull the power plug out of the wall socket. Consequently, the power plug must be easily and readily accessible at all times

Wiring the Main Power Supply Plug (UK Only)

IMPORTANT NOTICE

The mains lead on this equipment is supplied with a moulded plug incorporating a fuse. The value of the fuse is indicated on the pin face of the plug and if it requires replacing, a fuse approved to BS1362 of the same rating must be used.

Never use the plug with the fuse cover removed. If the cover is detachable and a replacement is required, it must be of the same colour as the fuse fitted in the plug. Replacement covers are available from your dealer. If the fitted plug is not suitable for the power points in your house or the cable is not long enough to reach a power point, you should obtain a suitable safety approved extension lead or consult your dealer for assistance. However, if there is no alternative to cutting off the plug, remove the fuse and then safely dispose of the plug. Do not connect the plug to a mains socket as there is a risk of shock hazard from the bared flexible cord. Never attempt to insert bare wires directly into a mains socket. A plug and fuse must be used at all times.

IMPORTANT

The wires in the mains lead are coloured in accordance with the following code: - BLUE = NEUTRAL BROWN = LIVE As these colours may not correspond to the coloured markings identifying the terminals in your plug, proceed as follows: - The wire coloured BLUE must be connected to the terminal marked with the letter N or coloured BLUE or BLACK. The wire coloured BROWN must be connected to the terminal marked with the letter L or coloured BROWN or RED.

WARNING: DO NOT CONNECT EITHER WIRE TO THE EARTH TERMINAL WHICH IS MARKED WITH THE LETTER E OR BY THE EARTH SYMBOL , OR COLOURED GREEN OR GREEN AND YELLOW.

PRECAUTIONS

- Ensure that the AC power supply in your house complies with the power requirements listed on the identification sticker located on the bottom of your product. Install your product horizontally, on a suitable base (furniture), with enough space around it for ventilation (7-10 cm). Make sure the ventilation slots are not covered. Do not place the unit on amplifiers or other equipment which may become hot. This unit is designed for continuous use. To fully turn off the unit, disconnect the AC plug from the wall outlet. Unplug the unit if you intend to leave it unused for a long period of time.
- During thunderstorms, disconnect the AC plug from the wall outlet. Voltage peaks due to lightning could damage the unit.
- Do not expose the unit to direct sunlight or other heat sources. This could lead to overheating and cause the unit to malfunction.

04 USING A WIRED CONNECTION

	1	HDMI Cable (not supplied)
	2	Optical Cable (not supplied)

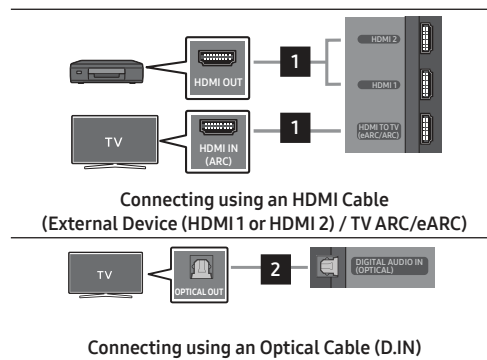

NOTE

- When the TV sound is not output, press the **(Multi Function)** button at the top of the Soundbar or the **(Source)** button on the remote control to select the "D.IN" mode. The screen displays "D.IN" and "TV ARC/eARC" in sequence, and TV sound is played.
- The recommended cable is a **Premium High Speed HDMI Cable with Ethernet** certified by HDMI.org.
- When you use an optical cable and the terminals have covers, be sure to remove the covers.

Using the Q-Symphony Function

When the Soundbar connects to a Samsung TV that supports the Q-Symphony function you can play the sound simultaneously through the Soundbar and the TV. If you use the Q-Symphony function, the surround sound played on the TV allows you to enjoy a richer, more three-dimensional surround sound effect. When the Soundbar is connected "TV+Soundbar" menu appears on the TV. (Settings (⚙) → All Settings (⚙) → Sound → Sound Output)

Using the SpaceFit Sound

This function analyzes the user's listening space with the Soundbar's microphone and provide optimal sound for the space. Sound optimization proceeds automatically.

05 USING A WIRELESS CONNECTION

Connecting via Bluetooth

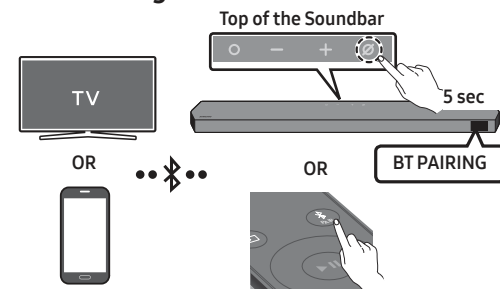

What is the difference between BT READY and BT PAIRING?

- BT READY**: In this mode, you can reconnect any Samsung TV or mobile device that was connected before.
- BT PAIRING**: In this mode, you can connect a new device to the Soundbar. (Press the **PAIR** button on the Soundbar remote control or press and hold the **(Mic On/Off)** button on the top of the Soundbar for more than 5 seconds while the Soundbar is in "BT" mode.)

NOTE

- If asked for a PIN code when connecting a Bluetooth device, enter <0000>.

Connecting via Wi-Fi (Wireless Network)

- To connect a Soundbar to a mobile device via a wireless network (Wi-Fi), the **SmartThings** app is required.
- Connect your mobile device (smartphone, tablet, etc.) to the Wi-Fi network the TV is connected to.
 - Install and launch the **SmartThings** app on your mobile device (smartphone, tablet, etc.).
 - Follow the instructions in the app screen on the mobile device to connect the Soundbar to your Wi-Fi network.

06 TROUBLESHOOTING

Before seeking assistance, check the following.

Soundbar does not turn on.

- Check whether the power cord of the Soundbar is correctly inserted into the outlet.

When the subwoofer or surround sound speakers are not automatically connected

- Turn off the Soundbar main unit.
- Press and hold **ID SET** on the rear of the subwoofer and surround speakers for at least 5 seconds.

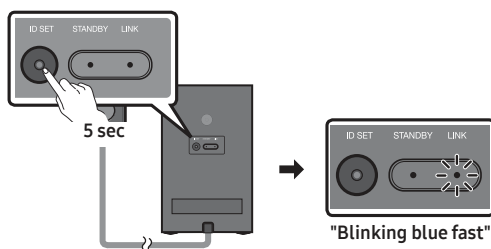
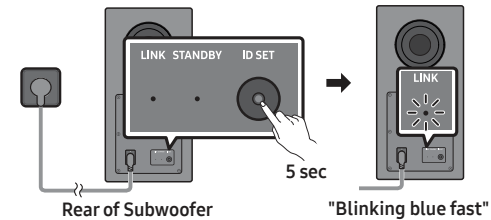

- Press the **Up** button on the remote control for 5 seconds.

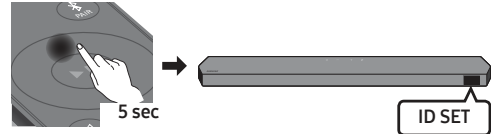

- Check if the **LINK** LED is solid blue (connection complete).
 - The **LINK** LED indicator stops blinking and glows a solid blue when a connection is established between the Soundbar and the Subwoofer, surround speakers.

Soundbar works erratically.

- After removing the power cord, insert it again.
- Try again after initialising the product.
- If there is no signal, the Soundbar automatically turns off after a certain period of time. Turn on the power.

Remote control does not work

- Point the remote directly at the soundbar.
- Replace the batteries with new ones.

The Soundbar indicator turns solid red.

- The microphone is turned off. Turn on the microphone.

Sound is not output from the soundbar.

- The volume of the Soundbar is too low or muted. Adjust the volume.
- When any external device (STB, Bluetooth device, mobile device, etc.) is connected, adjust the volume of the external device.
- For sound output of the TV, select Soundbar. (Samsung TV: Home () → Menu → Settings () → All Settings () → Sound → Sound Output → Select Soundbar)
- Remove the cable from the Soundbar and then reconnect it.

Sound is not output from the subwoofer or the surround speakers.

- Check whether the LED on the rear of the Subwoofer and Surround Speakers lights in blue. Reconnect it when the blue LED blinks or the red LED lights.

If the TV is not connected via HDMI to TV (eARC/ARC)

- Check whether the HDMI cable is correctly connected to the ARC terminal.
- Connection may not be possible due to the connected external device (set-top box, game console, etc.). Directly connect the Soundbar.
- HDMI-CEC may not be activated on the TV. Turn on the CEC on the TV menu. (Samsung TV: Home () → Menu → Settings () → All Settings () → Connection → External Device Manager → Anynet+ (HDMI-CEC) ON)

Soundbar will not connect via Bluetooth.

- When connecting a new device, switch to "BT PAIRING" for connection. (Press the **PAIR** button on the remote control or press the **(Mic On/Off)** button on the body for at least 5 seconds.)
- Reconnect it after removing the Bluetooth speaker list on the device to connect. (Samsung TV: Home () → Menu → Settings () → All Settings () → Sound → Sound Output → Bluetooth Speaker List)

Sound drops out when connected via Bluetooth.

- Some devices can cause radio interference if they are located too close to the Soundbar. e.g. microwaves, wireless routers, etc.
- If your device that is connected via Bluetooth moves too far away from the soundbar, it may cause the sound to drop out. Move the device closer to the soundbar.
- If a part of your body is in contact with the Bluetooth transceiver or the product is installed on metal furniture, the sound may drop out. Check the installation environment and conditions for use.

Soundbar will not connect to Wi-Fi.

- Make sure the wireless router is turned on and then reconnect the wireless router after rebooting.
- The soundbar will not connect if the wireless signal is too weak. Try moving the router closer to the soundbar, or eliminating any obstacles that are between the soundbar and the router, if possible.

The soundbar does not turn on automatically with the TV.

- When you turn off the Soundbar while watching TV, power synchronization with the TV is disabled. First turn off the TV.

07 LICENCE



Dolby, Dolby Atmos, and the double-D symbol are registered trademarks of Dolby Laboratories Licensing Corporation. Manufactured under license from Dolby Laboratories. Confidential unpublished works. Copyright © 2012-2021 Dolby Laboratories. All rights reserved.



For DTS patents, see <http://patents.dts.com>. Manufactured under license from DTS, Inc. (for companies headquartered in the U.S./Japan/Taiwan) or under license from DTS Licensing Limited (for all other companies). DTS, DTS:X, and the DTS:X logo are registered trademarks or trademarks of DTS, Inc. in the United States and other countries. © 2021 DTS, Inc. ALL RIGHTS RESERVED.



The terms HDMI and HDMI High-Definition Multimedia Interface, and the HDMI Logo are trademarks or registered trademarks of HDMI Licensing Administrator, Inc. in the United States and other countries.



- Use your phone, tablet or computer as a remote control for Spotify. Go to spotify.com/connect to learn how
- The Spotify Software is subject to third party licenses found here: <https://www.spotify.com/connect/third-party-licenses>.

To send inquiries and requests for questions regarding open sources, contact Samsung Open Source (<http://opensource.samsung.com>)



- Apple, Airplay, iPhone, iPad, and Mac are trademarks of Apple Inc., registered in the U.S. and other countries.
- Use of the Works with Apple badge means that an accessory has been designed to work specifically with the technology identified in the badge and has been certified by the developer to meet Apple performance standards.

08 IMPORTANT NOTES ABOUT SERVICE

- Figures and illustrations in this User Manual are provided for reference only and may differ from actual product appearance.
- An administration fee may be charged if either (a) an engineer is called out at your request and there is no defect with the product (i.e. where the user manual has not been read), (b) you bring the unit to a repair centre and there is no defect with the product (i.e. where the user manual has not been read).
- You will be informed of the administration fee amount before a technician visits.

09 SPECIFICATIONS AND GUIDE

Model Name	
HW-Q990C	
Weight	Dimensions (W x H x D)
7.7 kg	1232.0 x 69.5 x 138.0 mm
Operating Temperature Range	Operating Humidity Range
+10 °C to +40 °C	10 % to 80 %, non-condensing
Storage Temperature	Storage Humidity
-20 °C to +45 °C	5 % to 95 %, non-condensing
AMPLIFIER	
Rated Output power	
(18 W x 4) + (10 W x 2) + (18 W x 2) + (10 W x 1) + (18 W x 6)	
Supported play formats	
Dolby 5.1ch / Dolby Digital Plus / Dolby TRUE HD / Dolby ATMOS / DTS 5.1ch / DTS HD / DTS-HD Master Audio / DTS:X / LPCM 8Ch	

Subwoofer Name	
PS-WC99B	
Weight	Dimensions (W x H x D)
11.7 kg	220.0 x 413.0 x 410.0 mm

AMPLIFIER	
Rated Output power	
200 W	

Surround Speaker Name	
PS-RC99B (LEFT/RIGHT)	
Weight	Dimensions (W x H x D)
3.4 kg	129.5 x 201.3 x 140.4 mm

AMPLIFIER	
Rated Output power	
210 W	

NOTE

- Samsung Electronics Co., Ltd reserves the right to change the specifications without notice.
- Weight and dimensions are approximate.

Precaution : The Soundbar will restart automatically if you turn on/turn off Wi-Fi.

Overall Standby Power Consumption (W)
7.7 W

Wi-Fi Port deactivation method

Press the **CH LEVEL** button on the remote control of the Soundbar for 30 seconds to turn Wi-Fi On / Off.

Bluetooth Port deactivation method

Press the **TONE CONTROL** button on the remote control of the Soundbar for 30 seconds to turn Bluetooth On / Off.

- Hereby, Samsung declares that this radio equipment is in compliance with Directive 2014/53/EU and the relevant UK statutory requirements. The full text of the declaration of conformity is available at the following internet address: <http://www.samsung.com> go to Support and enter the model name. This equipment may be operated in all EU countries and in the UK. The 5GHz WLAN(Wi-Fi or SRD) function of this equipment may only be operated indoors.
- WIRELESS DEVICE OUTPUT POWER**
 - RF max transmitter power**
 - 100mW at 2.4GHz-2.4835GHz
 - 200mW at 5.15GHz-5.25GHz & 5.47GHz - 5.725GHz
 - 100mW at 5.25GHz-5.35GHz
 - 25mW at 5.725GHz-5.875GHz

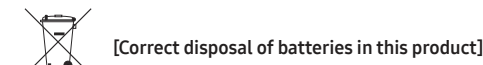

(Applicable in countries with separate collection systems)

This marking on the battery, manual or packaging indicates that the batteries in this product should not be disposed of with other household waste at the end of their working life. Where marked, the chemical symbols Hg, Cd or Pb indicate that the battery contains mercury, cadmium or lead above the reference levels in EC Directive 2006/66.

If batteries are not properly disposed of, these substances can cause harm to human health or the environment. To protect natural resources and to promote material reuse, please separate batteries from other types of waste and recycle them through your local, free battery return system.

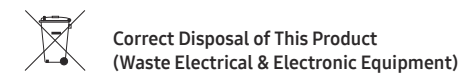

(Applicable in countries with separate collection systems)

This marking on the product, accessories or literature indicates that the product and its electronic accessories (e.g. charger, headset, USB cable) should not be disposed of with other household waste at the end of their working life. To prevent possible harm to the environment or human health from uncontrolled waste disposal, please separate these items from other types of waste and recycle them responsibly to promote the sustainable reuse of material resources. Household users should contact either the retailer where they purchased this product, or their local government office, for details of where and how they can take these items for environmentally safe recycling. Business users should contact their supplier and check the terms and conditions of the purchase contract. This product and its electronic accessories should not be mixed with other commercial wastes for disposal.

For information on Samsung's environmental commitments and product specific regulatory obligations e.g. REACH, WEEE, Batteries, visit: www.samsung.com/uk/aboutsamsung/sustainability/environment/our-commitment/data/



This Samsung product is warranted for the period of twelve (12) months from the original date of purchase, against defective materials and workmanship. In the event that warranty service is required, you should return the product to the retailer from whom it was purchased. However, Samsung Authorised Dealers and Authorised Service Centres in other EC Countries will comply with the warranty on the terms issued to purchasers in the country concerned. In case of difficulty, details of our Authorised Service Centres are available from:

Samsung Electronics U.K. Ltd
Samsung Customer Support Centre
Selectapost 38, Sheffield, S97 3FJ
United Kingdom

United Kingdom
Tel : 0333 000 0333
www.samsung.com/uk/support

EIRE
Tel : 0818 717100
www.samsung.com/ie/support

WARRANTY CONDITIONS

- The warranty is only valid if, when warranty service is required, the warranty card is fully and properly completed and is presented with the original invoice or sales slip or confirmation, and the serial number on the product has not been defaced.
- Samsung's obligations are limited to the repair or, at its discretion, replacement of the product or the defective part. Repaired or replaced products may include new and/or refurbished components and equipment.
- Warranty repairs must be carried out by Authorised Samsung Dealers or Authorised Service Centres. No re-imbursalment will be made for repairs carried out by non Samsung Dealers and, any such repair work and damage to the products caused by such repair work will not be covered by this warranty.



- This product is not considered to be defective in materials nor workmanship by reason that it requires adaptation in order to conform to national or local technical or safety standards in force in any Country other than the one for which the product was originally designed and manufactured. This warranty will not cover, and no re-imbursalment will be made for such adaptation nor any damage which may result.
- This warranty covers none of the following:
 - Periodic check ups, maintenance and repair or replacement of parts due to normal wear and tear.
 - Cost relating to transport, removal or installation of the product.
 - Misuse, including the failure to use this product for its normal purposes or incorrect installation.
 - Damage caused by Lightning, Water, Fire, Acts of God, War, Public Disturbances, incorrect mains voltage, improper ventilation or any other cause beyond the control of Samsung.
- This warranty is valid for any person who legally acquired possession of the product during the warranty period.
- The consumers' statutory rights in any applicable national legislation whether against the retailer arising from the purchase contract or otherwise are not affected by this warranty. Unless there is national legislation to the contrary, the rights under this warranty are the consumers' sole rights and Samsung, its subsidiaries and distributors shall not be liable for indirect or consequential loss or any damage to disc based media, removable memory or any other related equipment or material.
- Samsung shall honour warranties for all EU specification products purchased by a consumer within the following European countries listed.
 - UK, Republic of Ireland, Germany, France, Italy, Malta, Spain, Portugal, The Netherlands, Belgium, Luxembourg, Denmark, Sweden, Finland, Poland, Hungary, Czech Republic, Slovakia, Austria, Slovenia, Croatia, Estonia, Latvia, Lithuania, Greece, Cyprus, Romania, Bulgaria, Switzerland, Norway, Lichtenstein and Iceland.